



Office Furniture Collection





THE DESIGN COMPANY

Ebony & Ivory is a design company that was established in Cairo, Egypt in October 1997.

At the early beginnings, the company was focused on designing interiors with a scope of work that covered both residential and contract spaces. Throughout the years, due to Ebony & Ivory's passion for design, creation and experimentation the company's scope of work evolved into a broader range that currently includes furniture design, furniture production, interior architecture, and general architectural project consultancy.

At Ebony & Ivory we truly believe in teamwork, living in the present moment and listening carefully to our clients' operational and functional requirements, as well as their aesthetic preferences.

Our style and design philosophy have been changing over the years, constantly evolving into an updated version. If there is a constant throughout the evolution process with Ebony & Ivory's paradigm of thought that would be the ongoing challenge to embrace change and endorse fusion.





THE FACTORY

Located in the 10th of Ramadan industrial city, our factory is a furniture production facility that specializes in residential furniture, contract furniture, hospitality, and office furniture. The facility is built on a land plot with an area of 3600 sqm, with a total built up area equivalent to 5000 sqm including offices and stores.

The factory is divided into four divisions: the machinery division, the carpentry division, the wood staining and finishing division and the upholstery division. The facility is well laid out and designed to produce high quality products, with the capability of working on our standard products (Alphabet Home and Alphabet Office) while keeping two full production lines free for custom made hospitality projects.

We are also capable of offering prototyping services for other design houses, as well as working on bespoke fitted furniture.





THE STORY BEHIND

Alphabet is a Cairo-born furniture brand, conceived by Ebony & Ivory Design Studio through the process of tailoring bespoke pieces for specific clients and projects. Eclectic and versatile by nature, the collection draws inspiration from the experience of living in Cairo today; vibrant, layered, and ever-evolving.

Since 2004, Ebony & Ivory's furniture design department has been dedicated to product development and creative collaboration with renowned designers, continuously enriching the collection.

The Alphabet Office line was created to meet the needs of companies seeking distinction in a market dominated by conformity. Our ambition was to reimagine the office, not as a soulless corporate shell, but as a space that breathes, inspires, and connects. A place where design brings warmth, character, and a sense of belonging.

Our vision is to keep evolving in the field of product design, consistently offering original creations defined by superior quality and craftsmanship.

New pieces are currently in development, with ongoing experimentation pushing the boundaries of form and function.





P R O D U C T S

OPEN **AREA**

EXECUTIVE **OFFICE**

COMMON **SPACE**

01



OPEN**AREA**

Workstations

Storage

Cubicles



01 | Workstations



Workbench Line I

Workbench Line I

Designed by: Ebony & Ivory Design Studio.



Presented: *Workbench Line I*
Face to face module for 4 people, black base with wood finish top.

The Work Bench Line 1 is a modular bench system featuring diverse sizes, angles, and shapes, offering designers the freedom to create dynamic open-space work halls, managerial setups, and private offices. This line's standout feature lies in its meticulously engineered metal components, ensuring robust mechanical fixation for enhanced durability and functionality. Attention to detail defines this system, with features such as optimized cable management to minimize clutter and maintain a clean, organized workspace. Work Bench Line 1 is designed to foster teamwork, interaction, and productivity, making it an ideal solution for modern work environments.

Materials : *MDF with high-pressure laminate and 2mm PVC trim, metal base and structure with an electrostatic finish.*

Presented: *Workbench Line I*
Face to face module for 6 people black base with wood finish top.



Workbench Line I

Face to Face Module

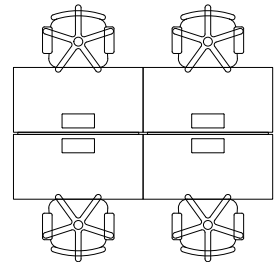

Presented: Workbench Line I
Face to Face Module for 4. available for 2, 4, 6, 8, or 10 persones



Materials: MDF with high pressure laminate and 2mm PVC trim, metal base and stucture with electrostatic finish.



Available with options for both side and front screens, or just a front screen, to cater to your specific interaction or privacy needs. Metal Base and structure available in black or white Top in MDF with high pressure laminate and 2mm PVC trim available in white or wood Finnish.



A sturdy articulated base ensures stability and allows for diverse configurations, while an integrated cabling rack keeps cables organized and clutter-free.



2 Face To Face Module

Face to Face Module available for 2, 4, 6, 8, or 10 persones



Work Bench Face to Face for 2



Work Bench Face to Face for 4



Work Bench Face to Face for 6



Workbench Line 1 Face to Face Module



OFFICE - Product





Workbench Line I

Curved Module



Materials: *MDF with high-pressure laminate and 2mm PVC trim, metal base and structure with an electrostatic finish.*



Screen made of wooden structure covered with fabric from both sides, connected with metal fingers to the metal structure.

3 Curved Module

Face to Face Module available for 2, 4, 6, 8, or 10 persones

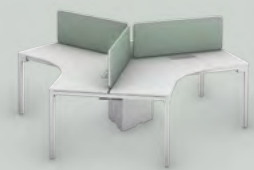

Work Bench Curved for 3

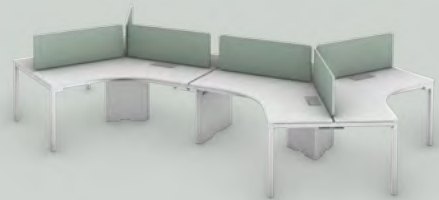

Work Bench Curved for 6

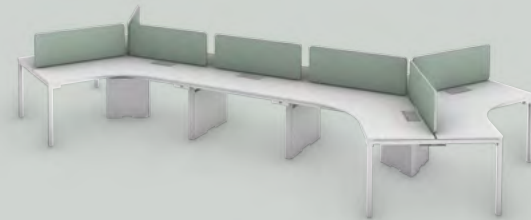

Work Bench Curved for 8



Workbench Line I

Curved Module



Materials : MDF with high-pressure laminate and 2mm PVC trim, metal base and structure with an electrostatic finish.



Office Products

Workbench Line I

Linear Module



Materials : *MDF with high-pressure laminate and 2mm PVC trim, metal base and structure with an electrostatic finish.*



Screen made of wooden structure covered with fabric from both sides, connected with metal fingers to the metal structure.

Linear Module

Linear Module available for 1, 2, 3 to 5 persones



Work Bench Linear for 1



Work Bench Linear for 2

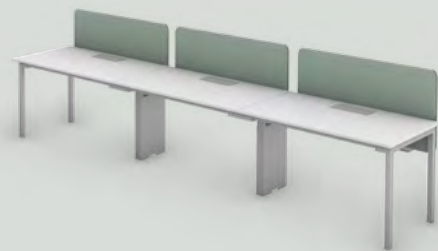

Work Bench Linear for 3



Workbench Line I

Linear Module



Materials : MDF with high-pressure laminate and 2mm PVC trim, Metal base and structure with an electrostatic finish.



Individual Desk

workbenchline

Workbench Line I

Individual Desk



A single desk with a side extension composed of the same modular elements of the Workbench Line I system. With the same features of sturdiness, flexibility and modularity a managerial set could be composed and possibly either integrated or split from the system whenever needed.



Workbench Line I

Individual Desk



Straight without Side extension



L Shape with Side extension

Technical Specifications

Straight without Side extension

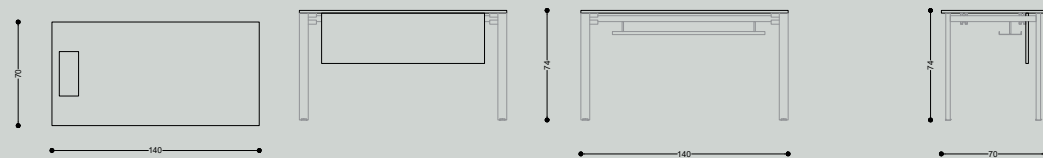

L Shape with Side extension

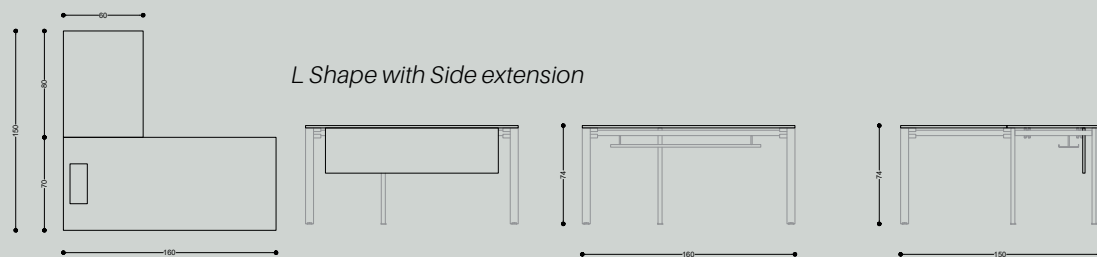



Workbench Line II



Workbench Line II

Designed by: Ebony & Ivory Design Studio.

Work Bench Line 2 is a modular bench system featuring diverse sizes, angles, and shapes, offering designers the freedom to create dynamic open-space work halls, managerial setups, and private offices. The main difference between this line and Work Bench 1 is that the drawer units are fixed, forming an integral structural element of the station and reducing the possibility of a messy look to the open space work environment. This line's standout feature lies in its meticulously engineered metal components, ensuring robust mechanical fixation for enhanced durability and functionality. Attention to detail defines this system, with features such as optimized cable management to minimize clutter and maintain a clean, organized workspace. Work Bench Line 2 is designed to foster teamwork, interaction, and productivity, making it an ideal solution for modern work environments.

Materials: *MDF with high pressure laminate and 2mm PVC trims, metal base and structure with electrostatic finish.*



Workbench Line II

Individual Desk



L Shape with Side Service Unit



Alphabet Office Products

Workbench Line II Individual Desk



L Shape with Side Service Unit



Materials: *MDF with high pressure laminate and 2mm PVC trims, metal base and structure with electrostatic finish.*



Materials: *MDF with high pressure laminate
And 2mm pvc trims, metal base and structure with electrostatic finish.*



Presented: *Workbench Line face to face for 4 peoples black base with wood finish top.*

Workbench LineII Face to Face Extensions



Presented: *Workbench Line face to face for 4 peoples black base with wood finish top.*



Workbench Line

The Collection

- 1. Work Bench Linear for 1
- 2. Work Bench Linear for 2
- 3. Work Bench Linear for 3
- 4. Work Bench Face to Face for 2
- 5. Work Bench Face to Face for 4
- 6. Work Bench Face to Face for 6

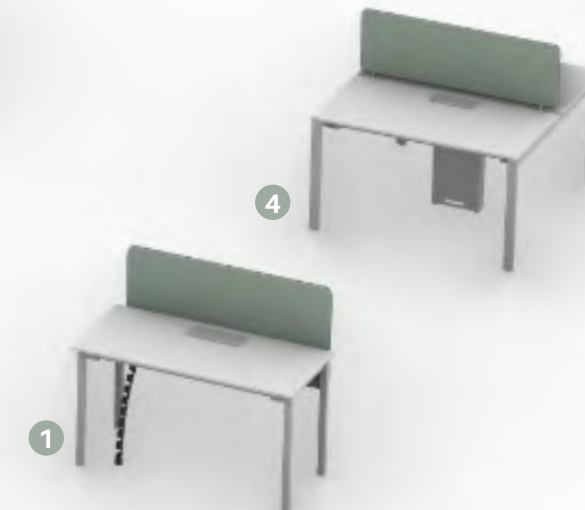
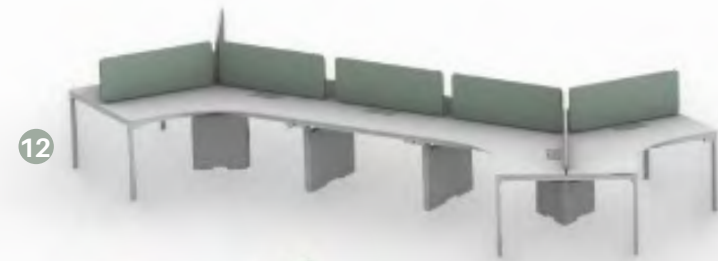

- 7. Work Bench Face to Face for 5
- 8. Work Bench L-Shape for 4
- 9. Work Bench Bench L-Shape for 4
- 10. Work Bench Curved for 3
- 11. Work Bench Curved for 6
- 12. Work Bench Curved for 8



C o n f i e l d



Cornfield

Designed by: Ebony & Ivory Design Studio.



This is a work station that enhances collaboration and communication between team members. The openness of the station is further emphasized by the middle planter, adding an element of greenery makes the station less formal and more inviting. On another note the wooden structure gives the station more elegance and makes it look like fine furniture. Middle separation screens made of solid Beech and Cane could be added for privacy. The station is fully equipped with cabling solutions.



Cornfield

Materials: Solid beech wooden frame and legs, metal supporting structure with electrostatic finish, MDF with high pressure laminate and 2mm PVC trims.





Comfield

With Screen



Products
Alphacel

Cornfield

With Screen



This is a work station that enhances collaboration and communication between team members. The openness of the station is further emphasized by the middle planter, adding an element of greenery makes the station less formal and more inviting. On another note the wooden structure gives the station more elegance and makes it look like fine furniture. Middle separation screens made of solid Beech and Cane could be added for privacy. The station is fully equipped with cabling solutions.



Cornfield

With Screen



Materials : Solid beech wooden frame and legs, metal supporting structure with electrostatic finish, MDF with high pressure laminate and 2mm PVC trims.



Cornfield High

Designed by: Ebony & Ivory Design Studio.



Materials : Solid beech wooden frame and legs, metal supporting structure with electrostatic finish, MDF with high pressure laminate and 2mm PVC trims.





Cornfield High

Designed by: Ebony & Ivory Design Studio.



Materials : Solid beech wooden frame and legs, metal supporting structure with electrostatic finish, MDF with high pressure laminate and 2mm PVC trims.



This is a work station that enhances collaboration and communication between team members. The high seating set up along with the openness of the station is further emphasized by the middle planter, adding an element of greenery makes the station less formal and more inviting. The station is fully equipped with cabling solutions.



Cornfield

The Collection

- 1. Cornfield Linear for 1
- 2. Cornfield Linear for 2
- 3. Cornfield Linear for 3
- 4. Cornfield Face to Face for 2
- 5. Cornfield Face to Face for 4
- 6. Cornfield Face to Face for 6

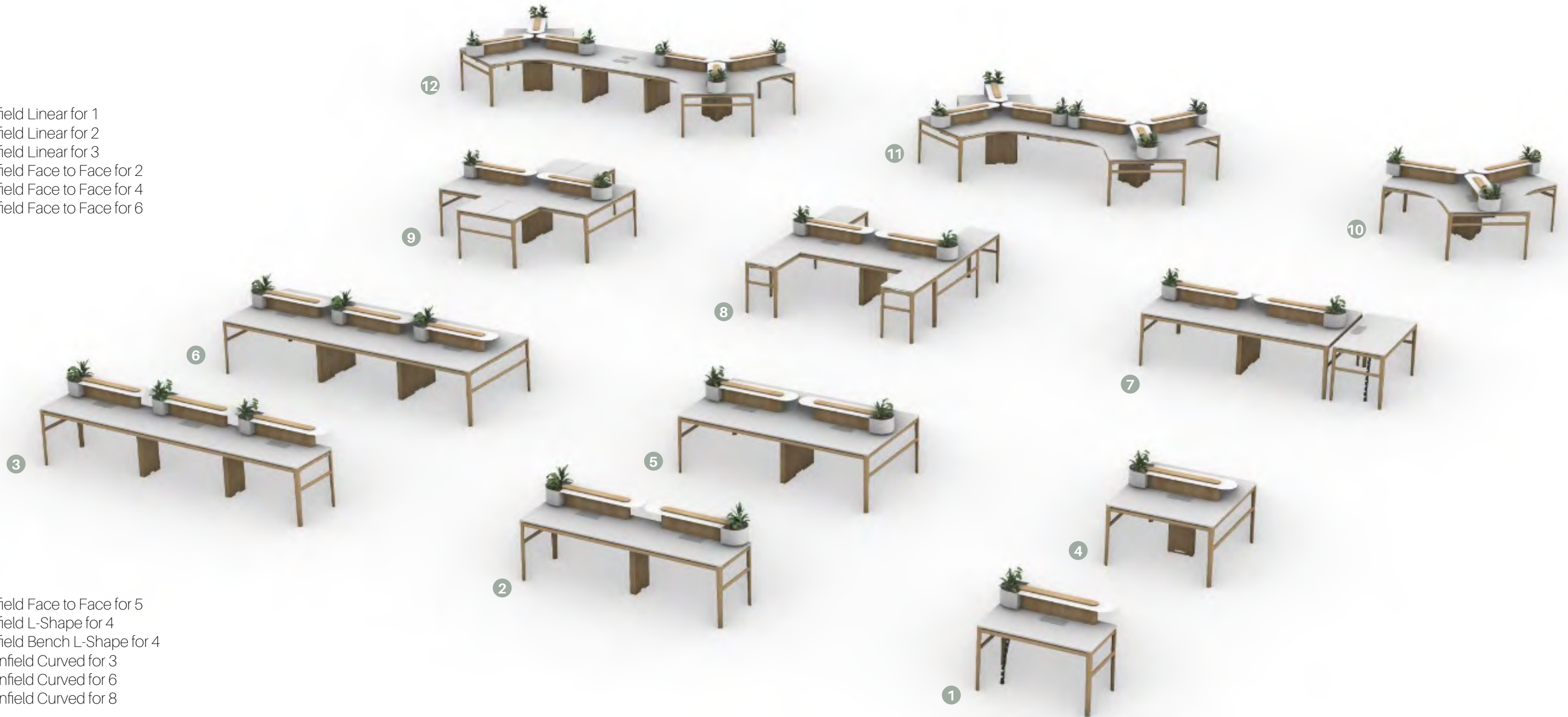

- 7. Cornfield Face to Face for 5
- 8. Cornfield L-Shape for 4
- 9. Cornfield Bench L-Shape for 4
- 10. Cornfield Curved for 3
- 11. Cornfield Curved for 6
- 12. Cornfield Curved for 8



W

L

L

G

A



Wilga

Designed by: Ebony & Ivory Design Studio.



The shape of this work station is dictated by its name, the old Wilga flying plane. The side view of the station is rendered with wooden buttons instead of visible bolts as seen in the original air plane. The middle spine has a wooden element that houses all electrical outlets, topped by either glass separators or fabric screens.



Wilga



Materials : *MDF with high pressure laminate and 2mm PVC trims, metal base and structure with electrostatic finish.*



FACILITY



Factory

Designed by: Ebony & Ivory Design Studio.



As the name of the station suggests, this line is fully built out of circular metal pipes, the structure also allows having the middle separators function for task lighting, screens could be added for privacy if needed. Factory is a modular workstation with different sizes and layout possibilities, fully equipped with cable trays and risers.



Factory

Designed by: Ebony & Ivory Design Studio.



Materials : *MDF with high pressure laminate and 2mm PVC trims, metal base and structure with electrostatic finish.*



Factory

The Collection

- 1. Factory Linear for 1
- 2. Factory Linear for 2
- 3. Factory Linear for 3
- 4. Factory Face to Face for 2
- 5. Factory Face to Face for 4
- 6. Factory Face to Face for 6

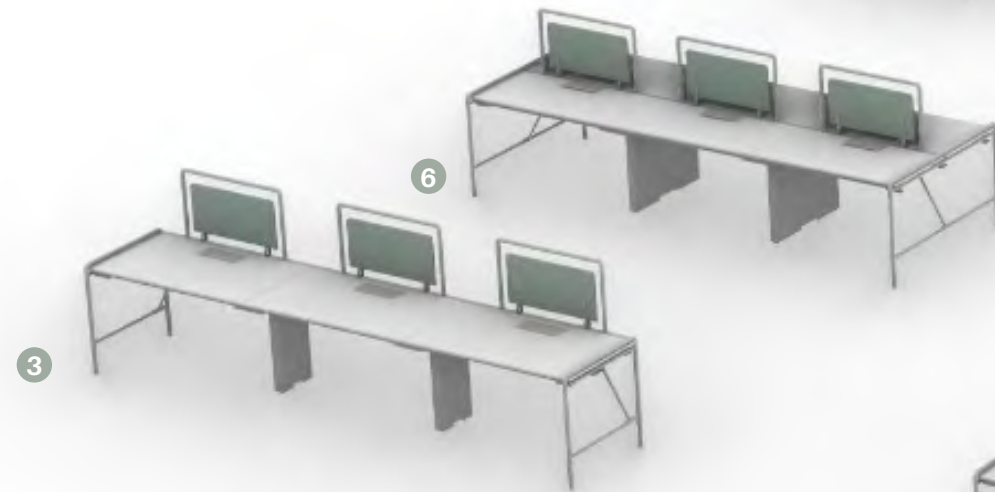
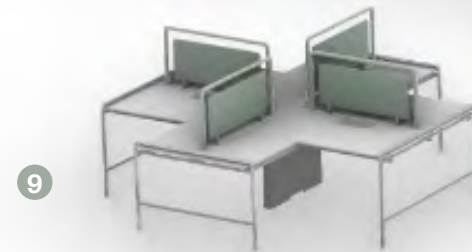
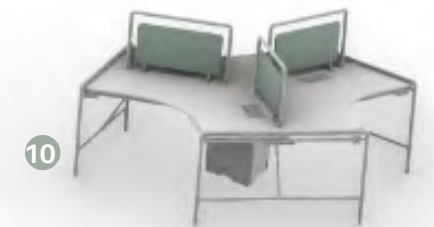
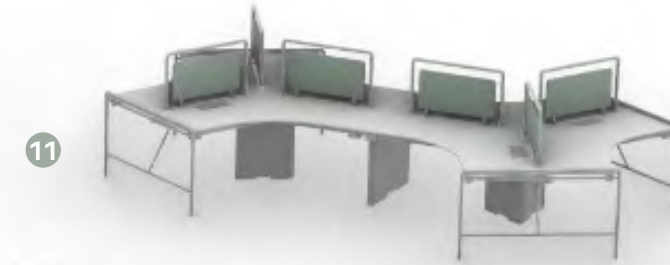
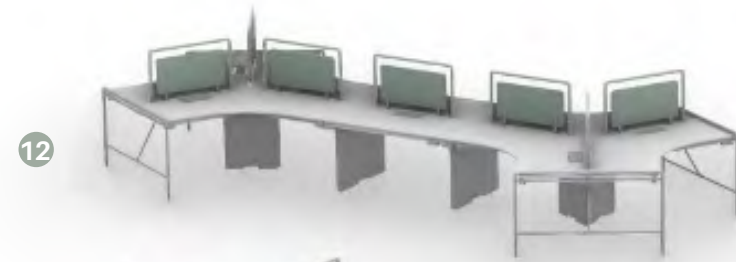

- 7. Factory Face to Face for 5
- 8. Factory L-Shape for 4 extended
- 9. Factory L-Shape for 4
- 10. Factory Curved for 3
- 11. Factory Curved for 6
- 12. Factory Curved for 8



Factory Individual Desk



Materials : *MDF with high pressure laminate
and 2mm PVC trims, metal base and structure with electrostatic finish.*



Technical Specifications

Straightt without Side extension

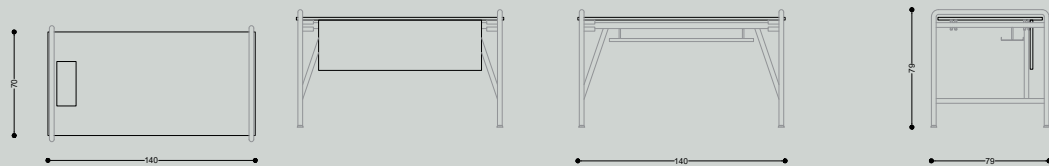

L Shape with Side extension

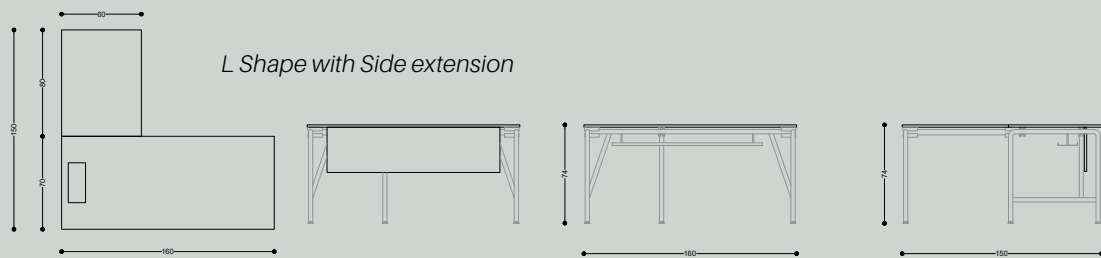

Factory Individual Desk



L Shape with Side extension



Straight without Side extension

Materials : MDF with high pressure laminate and 2mm PVC trims, metal base and structure with electrostatic finish.



Chronicles

Match Box

Match Box

Chronicles

02 | Storage

Match Box

Cornfield

Factory

Grid

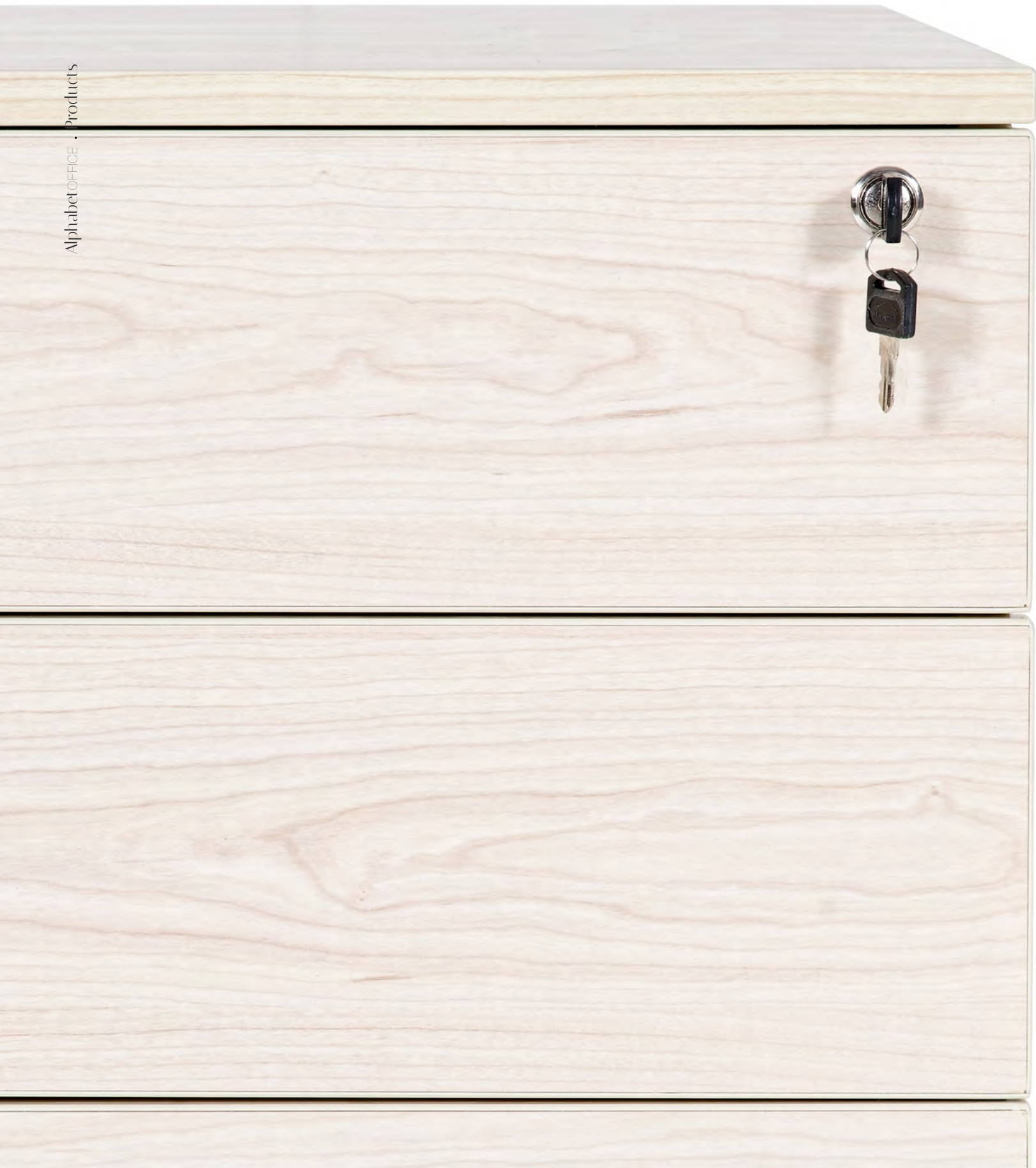

Chronicles

Designed by: Ebony & Ivory Design Studio.

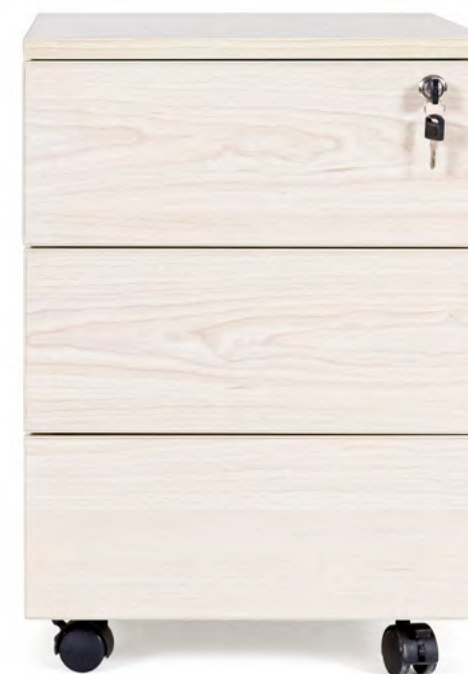

A versatile array of storage units, pedestals, and filing cabinets. These units accommodate both box files and hanging files. Available in three heights: low, medium, and high. Low units can be joined to create a larger credenza. Designed for maximum storage efficiency. This collection emphasizes modularity and functionality while maintaining an elegant design.

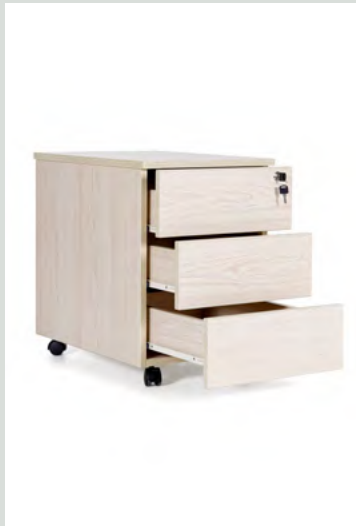

Chronicles



Technical Specifications

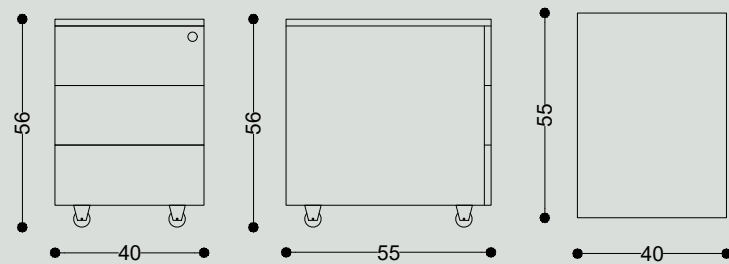

Materials:
MDF with high-pressure laminate.



Chronicles

Designed by: Ebony & Ivory Design Studio.



A versatile array of storage units, pedestals, and filing cabinets. These units accommodate both box files and hanging files. Available in three heights: low, medium, and high. Low units can be joined to create a larger credenza. Designed for maximum storage efficiency. This collection emphasizes modularity and functionality while maintaining an elegant design.

Alphabet OFFICE . Products



Technical Specifications

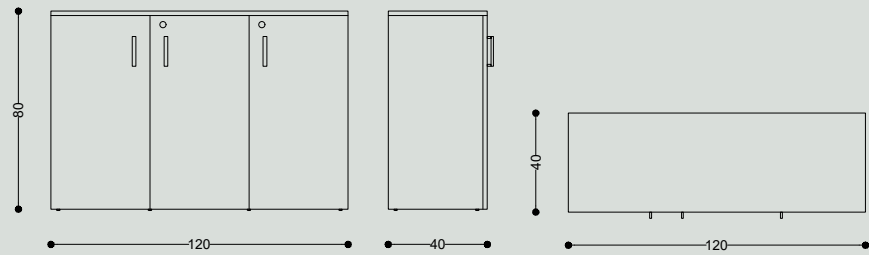

Chronicles



Materials: *MDF with high-pressure laminate.*



Match Box Shelving Unit

Designed by: Ebony & Ivory Design Studio.

Technical Specifications

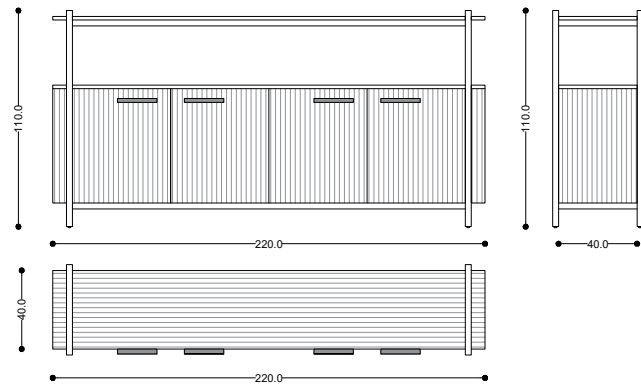

Materials: *MDF with a natural wood veneer, water base finish, metal structure with an electro-static coating.*



A versatile storage solution available as a sideboard or as a vertical shelving unit, it is ideal for breaking the monotony of typical office storage systems. Matchbox adds a visual relief in office layouts, an array of the vertical units could act as a partition, dividing a space into distinct zones for better space identification. Those shelving units are designed to both serve functionality while adding an appealing distinctive look to the space.



Match Box Shelving Unit

Designed by: Ebony & Ivory Design Studio.



Materials:
MDF with a natural wood veneer,
water base finish, metal structure with an electro-static coating.



Technical Specifications

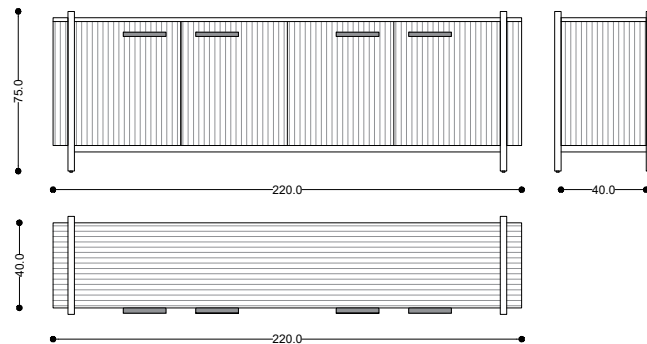

A versatile storage solution available as a sideboard or a vertical shelving unit. Ideal for breaking the monotony of traditional office storage. Adds visual relief in office layouts by replacing redundant storage units. Can act as a partition, dividing a space into distinct zones for better space identification. This shelving unit is designed for both functionality and aesthetic appeal, enhancing modern office environments.



Materials: *MDF with a natural wood veneer, water base finish, metal structure with an electro-static coating.*



Match Box Shelving Unit

Designed by: Ebony & Ivory Design Studio.



An alternative storage unit available either in the form of a sideboard or a vertical shelving unit. Matchbox could be used within the office layout to break the redundancy of the typical office storage units at certain areas, offering a bit of a visual relief. They could also be both used in the middle of a space dividing it into two zones, creating a visual partition for space identification.



Match Box Shelving Unit



Technical Specifications

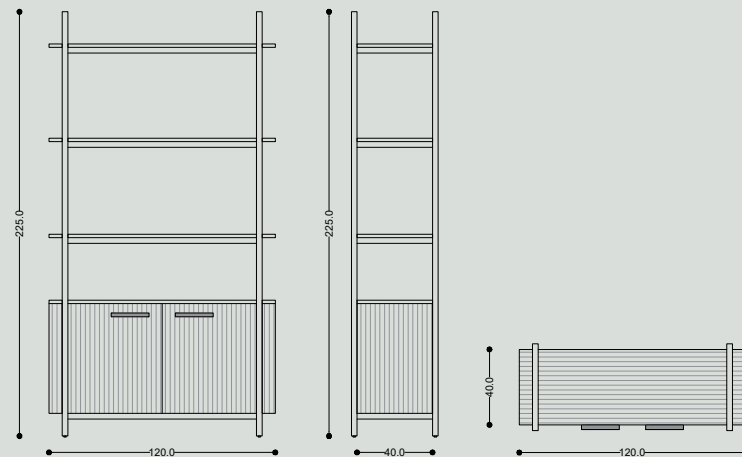

Materials: *MDF with a natural wood veneer. metal structure finished with an electro-static coating.*



Grid

Designed by: Ebony & Ivory Design Studio.



An elegant modular storage unit, composed of an array of open and closed compartments with sliding doors. At times it could also be used as a space separator to divide an open plan, it could serve as the divider between a meeting area and the actual desk space within an executive suite for instance, while still providing shelving and storage at the same time, serving both divisions at the same time.

Technical Specifications

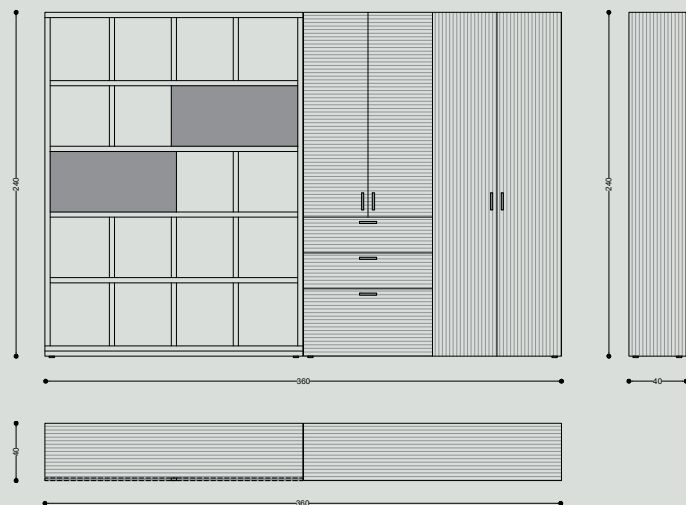

Grid



Materials: *MDF with natural wood veneer, water base finish.*



Cornfield

Designed by: Ebony & Ivory Design Studio.



A beautiful vertical unit with open shelves and closed compartments. The solid Beech supporting structure makes it look more of a fine furniture piece rather than a typical office furniture storage unit. Cornfield shelving could be either used within the same space with the Cornfield stations or separately within an office lounge or a break out area.



Technical Specifications

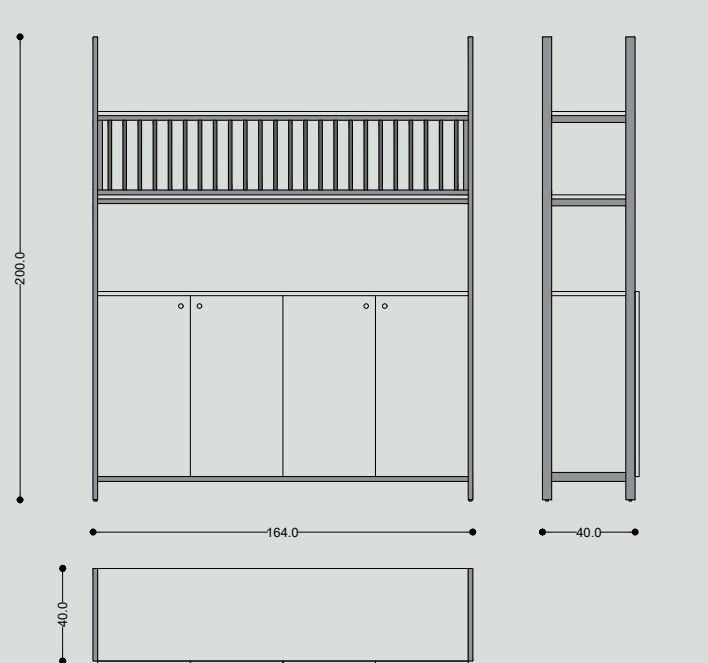

Cornfield



Materials : Solid Beech wooden frame and legs, MDF with high pressure laminate and 2mm PVC trims.



Factory

Designed by: Ebony & Ivory Design Studio.



Architectural storage cabinets composed of a tubular metal structure holding closed cabinets and open shelves. Besides the obvious functional aspects of the units they also adds an aesthetic feature to the office space. Available in a number of finishes and configurations.



Technical Specifications

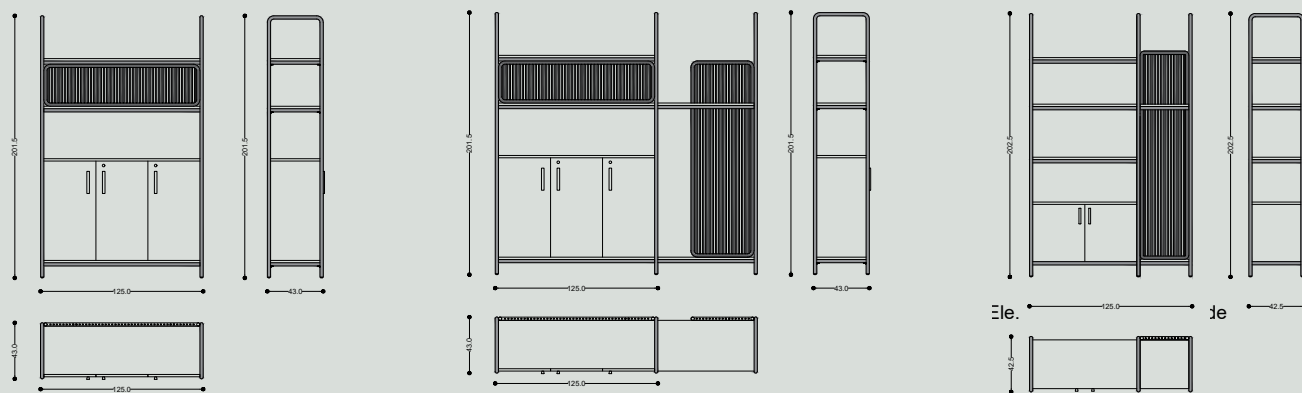

Factory



Materials : *MDF with high pressure laminate and 2mm PVC trims, metal base and structure with electrostatic finish.*





Cocoon

Designed by Ebony & Ivory Design Studio.



A new Panel system concept with its structure made entirely out of solid Beech wood, covered in straw mats with sound damping material stuffed inside. The concept is to create an earthy workstation using local materials that totally encapsulates the work space with privacy and functionality.



Cocoon



Materials: Solid Beech structure, rockwool stuffing for sound insulation, straw mats, MDF with high pressure laminate and 2mm PVC trims, metal cable runners.

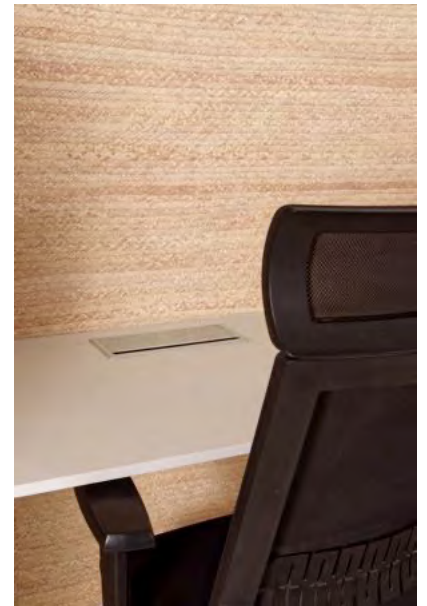





EXECUTIVE OFFICES

Desk

Credenza

Console & Bookshelves





Cage

Geo Quatro

Oval

Vencedor

01 | Desk

Troy

Curved

Architect

Slit

Diamond

Abstract

Origami

Fillet

Abstract

Designed by: Ebony & Ivory Design Studio.



A minimal design of a slim desk with straight lines and right angles, it can suite a variety of different styles of office spaces, yet still meet the requirements of a high end executive desk due to the use of very fine natural wood veneer.



Technical Specifications

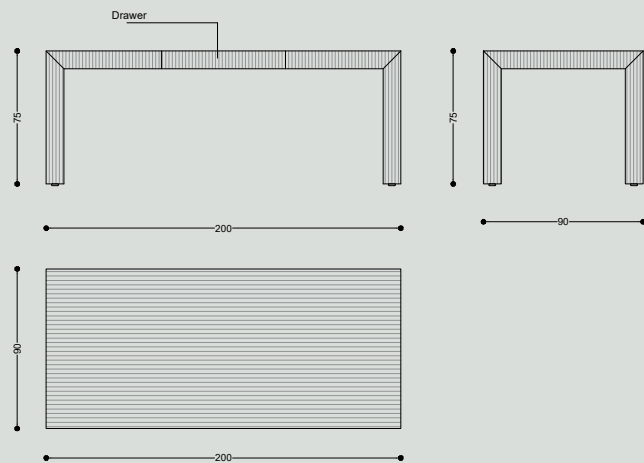

Abstract



Materials: Solid beech wood structure, MDF with natural wood veneer, water base finish.



Diamond



Diamond

Designed by: Ebony & Ivory Design Studio.



A unique executive table / desk that has a diamond shaped pattern crafted out of natural wood veneer, with its carefully detailed edges it adds richness and sophistication to the office in a subtle yet eyes catching manner.



Technical Specifications

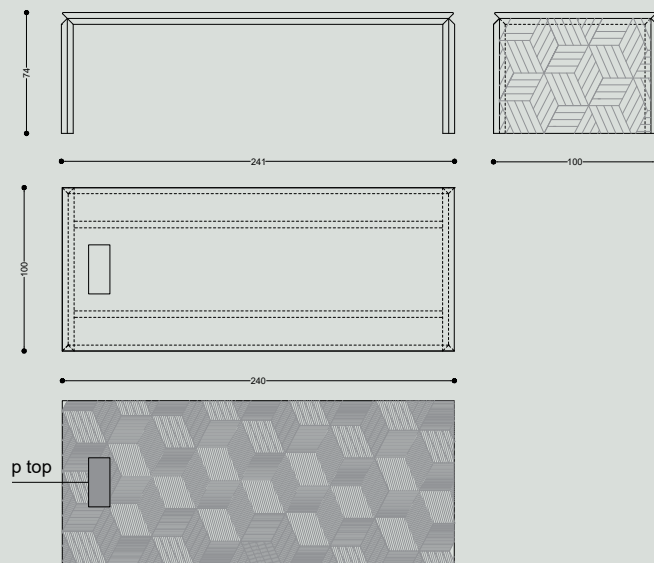

Diamond



Materials: Solid beech wood, MDF with natural wood veneer, water base finish.



SLIT

Designed by Ebony & Ivory Design Studio.



An upgrade for the traditional office desk design, using more attractive finishes and a leather covered top, making it quite suitable for higher management and top executives. The design is quite flexible making it fit easily within the interiors of most corporate managerial rooms.



Technical Specifications

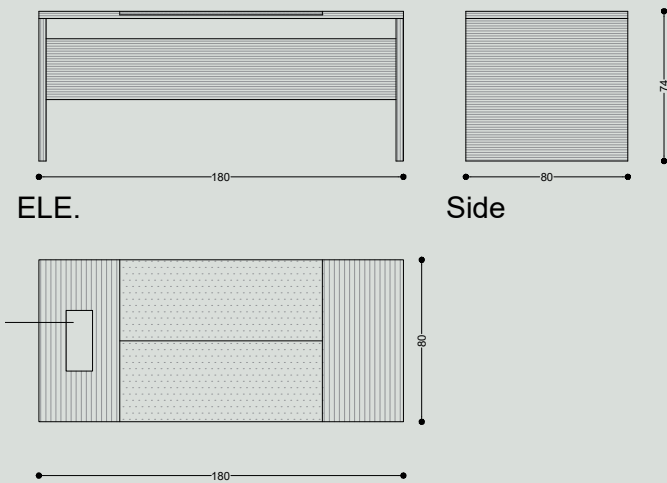

SLIT



Materials: *MDF with natural wood veneer, powder black lacquer, water base finish, leather.*





Ovalt



Oval

Designed by: Ebony & Ivory Design Studio.



The oval shape of the surface conveys a refined image that still implies status. The oval desk is a high-end executive desk set available with a side service unit that has three drawers and a storage cabinet for adequate storage. A modesty panel could be added underneath the surface for privacy, or it could be left exposed for a younger and more modern look.



Technical Specifications

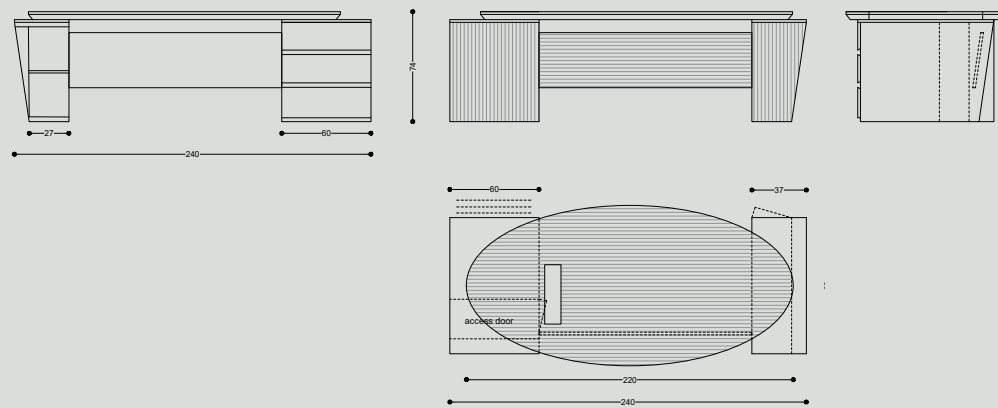

Oval

Designed by: Ebony & Ivory Design Studio.



Materials: *MDF with natural wood veneer, water base finish.*



afk



ORIGAMI



Origami

Designed by Ebony & Ivory Design Studio.



A rich and playful surface adorned with skillful Oak veneer work, while the base is formulated out of steel tubes looking like an abstraction of tree branches turned straight. The design of the table is formal yet cheerful, projecting an elegantly informal appearance. The infrastructure of the table is equipped with trays for power intercept units and cabling.



Technical Specifications

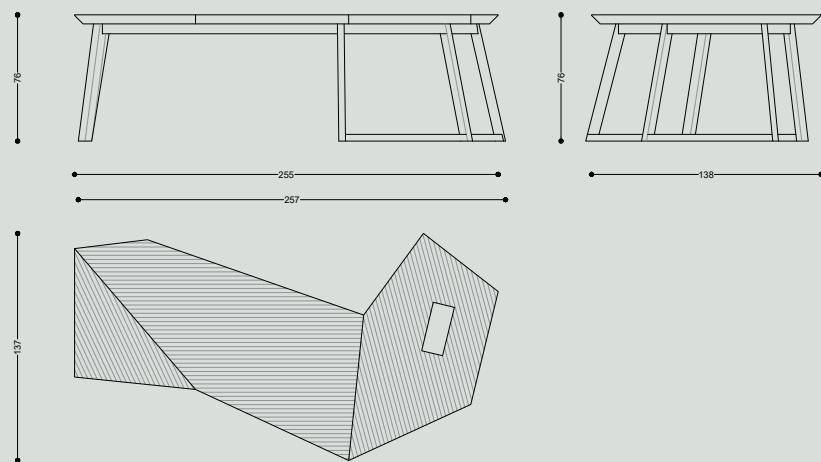

Origami



Materials : Metal structure with electrostatic finish, MDF with natural wood veneer, water base finish.





alpha
Office

Architect



Architect

Designed by: Ebony & Ivory Design Studio.



An elegant executive desk with a simple yet distinctive shape mainly achieved by the veneer pattern that runs on the surface as well as the side panel. The side service unit is quite functional and in full integration with the aesthetic of the desk.



Technical Specifications

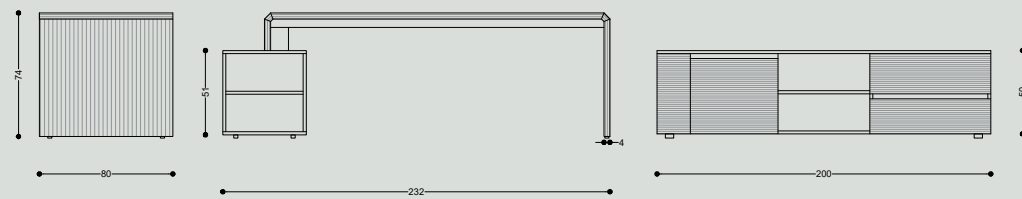

Ele.

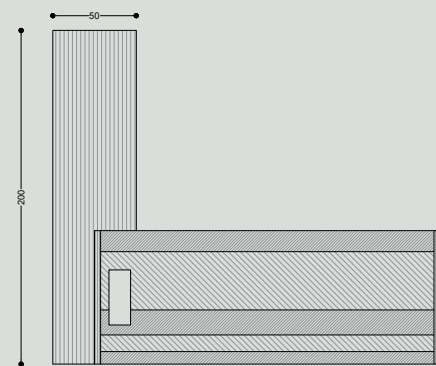

Architect



Materials: *MDF with natural wood veneer, water base finish.*



Curved

Designed by: Ebony & Ivory Design Studio.



A simple classic shape fully made of natural wood veneer with a side service unit containing drawers and shelves. The leather pad gives a managerial air to the desk, perfect for middle management where one may need a formal look with subtle luxury.



Technical Specifications

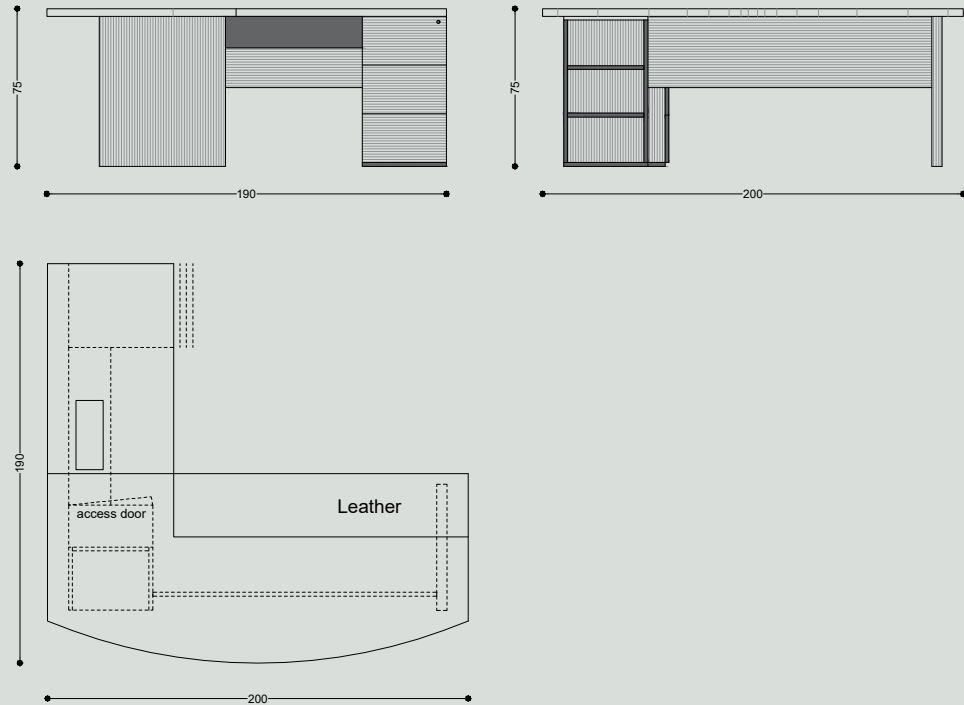

Curved



Materials: *MDF with natural wood veneer, water base finish, leather.*



TROY



Troy

Designed by Ebony & Ivory Design Studio.



A skillfully veneered surface resting on a shiny polished stainless steel base. The design is quite elegant and airy, with a functional side service unit that houses cabling solutions as well as plenty of storage.



Troy



Technical Specifications

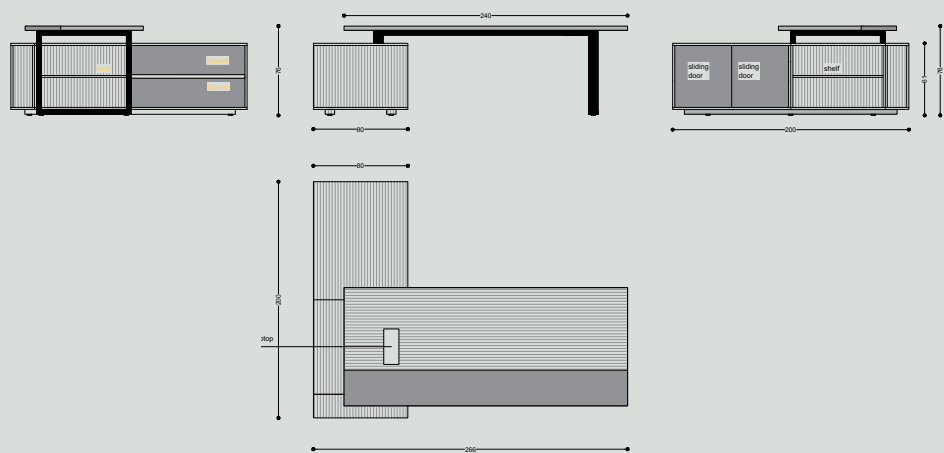

Materials : *Stainless steel structure, MDF with natural wood veneer, water base finish.*



Fillet



Fillet

Designed by: Ebony & Ivory Design Studio.



A more modern look for professional office desks, with its curvy design and spacious dimensions resulting in both comfort and elegance at the same time.



Fillet



Materials: *MDF with natural wood veneer.*

Technical Specifications

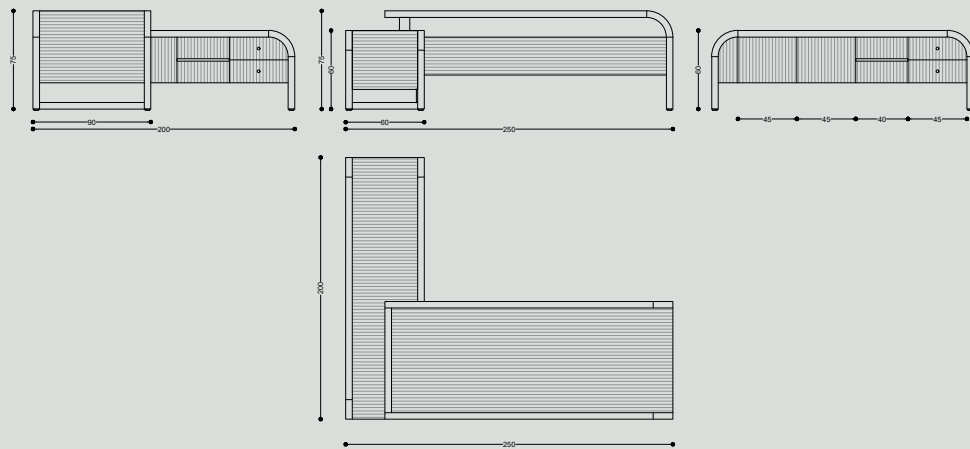



CAGE desk



CAGE DESK

Designer by Kyme.



Cage is a desk that rejuvenates human connection with nature. The product is inspired by the many organic shapes and textures found in vegetation. The natural wood grains give a smooth feel and texture, while the use of green mimics the delicate leaves.



CAGE DESK



Technical Specifications

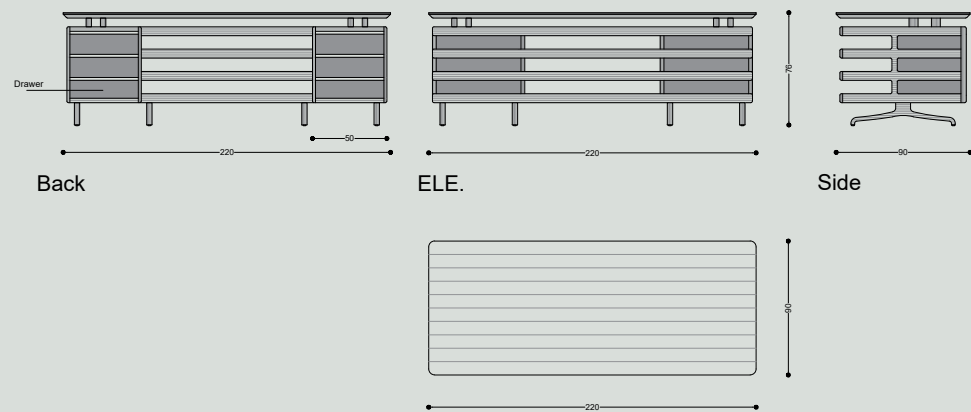

Materials : Solid beech structure, surface made of MDF with a layer of 1cm thick massive oak, painted plywood, water base finish.

Geo Quattro





Geo Quattro

Designed by Mahally.



The Geo Quattro desk is designed exclusively for CEOs, a prestigious yet minimalistic geometric design for luxurious offices. The concept of composing a piece of furniture with different matching materials together adds elegance and richness. The rectangular reconstituted stone top surface is the main focal element of this piece, around which all elements develop harmoniously. The PVD coated stainless steel inlays, drawers and storage units made out of natural oak veneer and the crystal glass top all make the desk more opulent. The desk is equipped with compartments for cables and built in sockets for cabling.



Technical Specifications

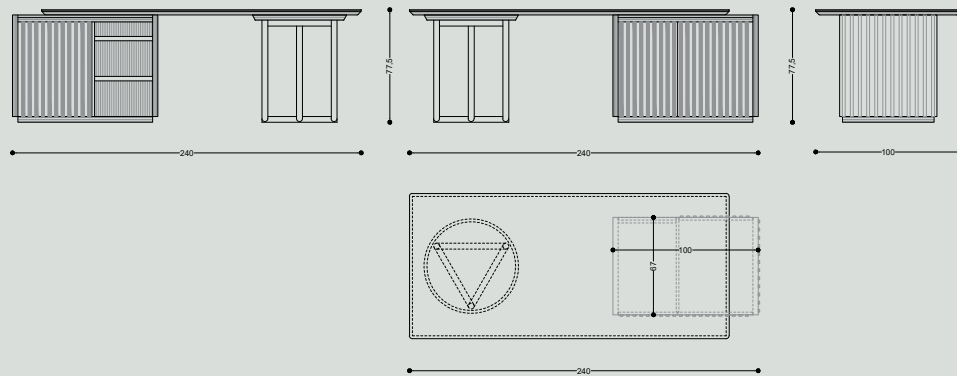

Geo Quatro



Materials : *MDF with natural wood veneer, PVD coated stainless steel base / inserts, reconstituted stone surface, 1.5 cm crystal glass, water base finish.*



Vencedor



Vencedor

Designed by Monty Design.



Powerful design in terms of all features. The design is inspired by the automotive industry with details that shed power, domination and status. This desk is quite big in size for an overpowering presence, with well detailed and luxurious storage facilities on either side.



Technical Specifications

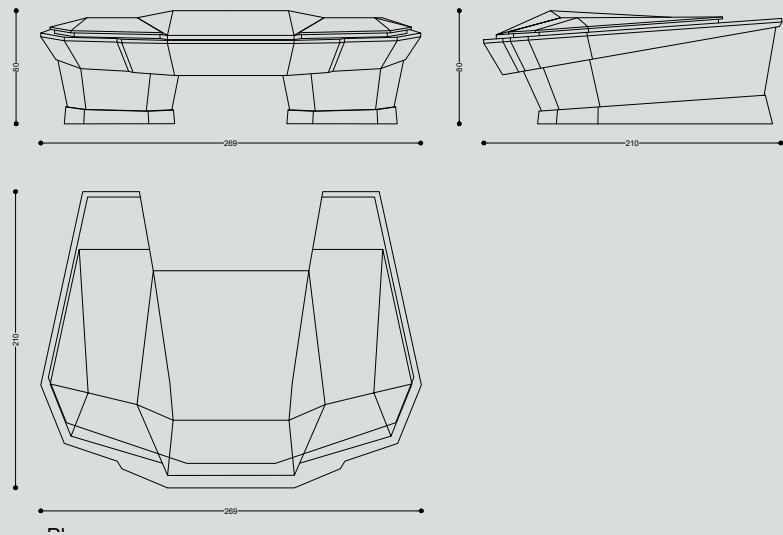

Vencedor



Materials : *MDF with natural wood veneer, water base stain finish, leather.*





Abstract

Vencedor

Origami

02 | Credenza

Geo Quatro

Diamond

Architect

Fillet



Abstract

Designed by Ebony & Ivory Design Studio.



A minimal design with simple lines and recesses, offering diverse storage solutions for high executives. With its straight lines and right angles this beautiful credenza can suite a variety of office contexts aesthetically, while still meet the needed functional requirements.



Technical Specifications

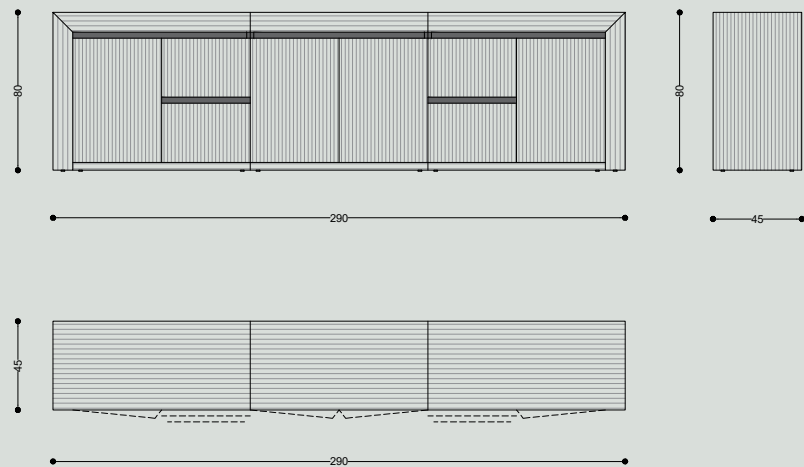

Abstract



Materials: Solid beech wood, MDF with natural wood veneer, water base finish.



Diamond

Designed by Ebony & Ivory Design Studio.



A matching functional credenza to be used either separately or with the Diamond desk, crafted out of natural wood veneer, with carefully detailed edges. This credenza adds richness and sophistication to the office in a subtle yet eyes catching manner, while at the same time it offers ample storage space for high executives.



Diamond



Technical Specifications

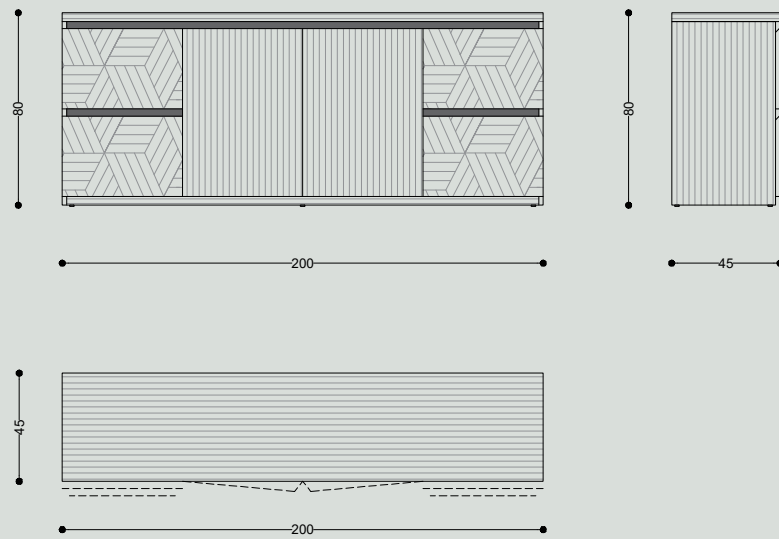

Materials: Solid beech wood, MDF with natural wood veneer, water base finish.



Origami

Designed by Ebony & Ivory Design Studio.



A rich and playful sideboard with a skilfully patterned surface made of natural Oak veneer. The design of the credenza is formal yet cheerful, projecting an elegantly informal appearance. Storage is carefully thought offering both cabinets and drawers for middle and high executives. This collection emphasizes modularity and functionality while maintaining an elegant design.





Technical Specifications

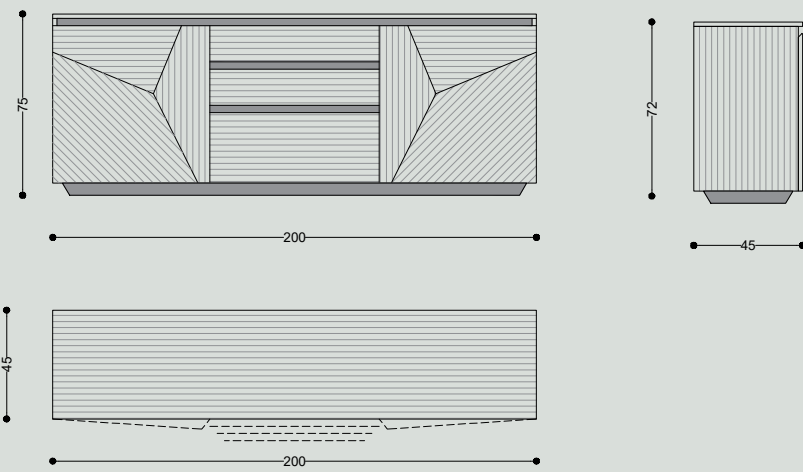

Origami



Materials: *MDF with natural wood veneer, water base finish.*





Architect

Designed by Ebony & Ivory Design Studio.

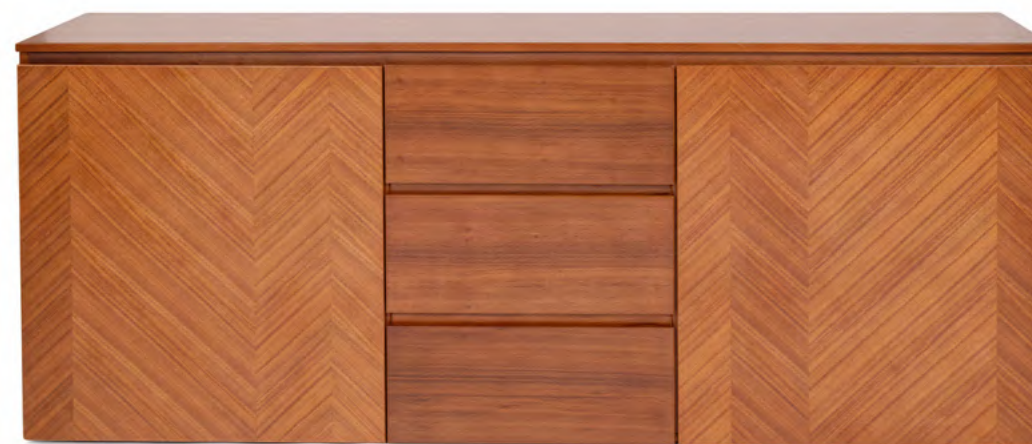

Inspired by the same intricate veneering pattern done for the Architect desk, offering multiple storage options with drawers and shelves. Perfect when matched with the Architect desk, and when used separately it still offers a subtle decorative aesthetic to the space.



Technical Specifications

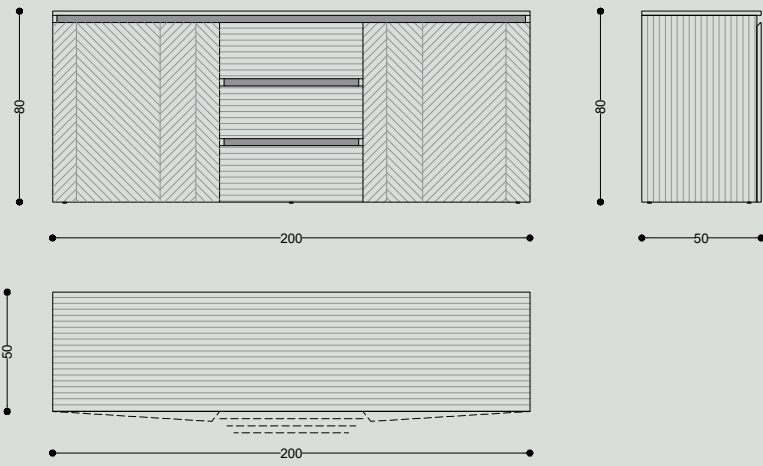

Architect



Materials : *MDF with natural wood veneer, water base finish.*



Fillet Credenza

Designed by: Ebony & Ivory Design Studio.



A more modern look for Professional storage/ filing unit, with its curvy design and spacious dimensions, This credenza provides more filing space to the executive office wrapped up with elegant design.



Fillet Credenza



Materials: Solid beech wood, MDF with natural wood veneer, water base finish

Technical Specifications

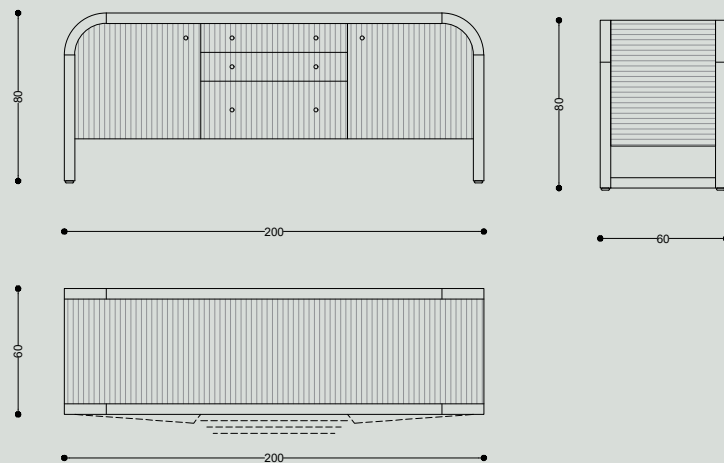



Geo Quattro

Designed by Mahally.



The Geoquattro Credenza is an elegant and rich looking piece of furniture that is specially formulated to match the Geoquattro desk, shedding an air of prestige and minimalism. Composed of three materials skillfully thought and joined together; natural Oak veneer, PVD coated stainless steel inlays and crystal glass, this credenza creates an elegant focal point in any executive room / lounge. The credenza offers ample functional storage space to any executive space.



Technical Specifications

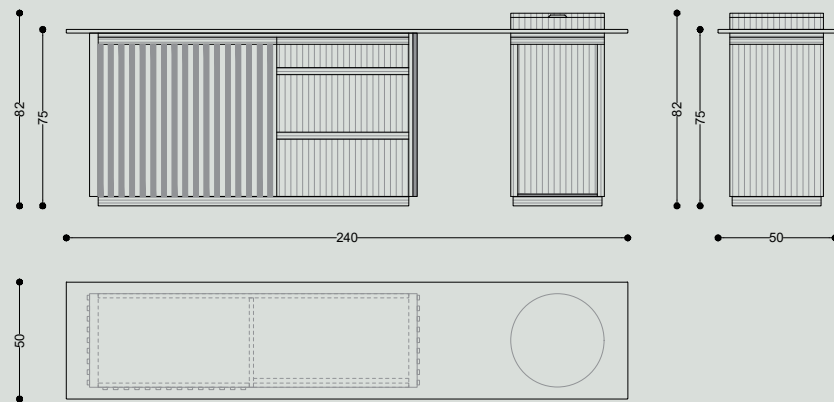

Geoquatro



Materials : *MDF with natural wood veneer,
PVD coated stainless steel base / inserts,
1.5cm crystal glass, water base finish.*



Vencedor

Designed by Monty Design.

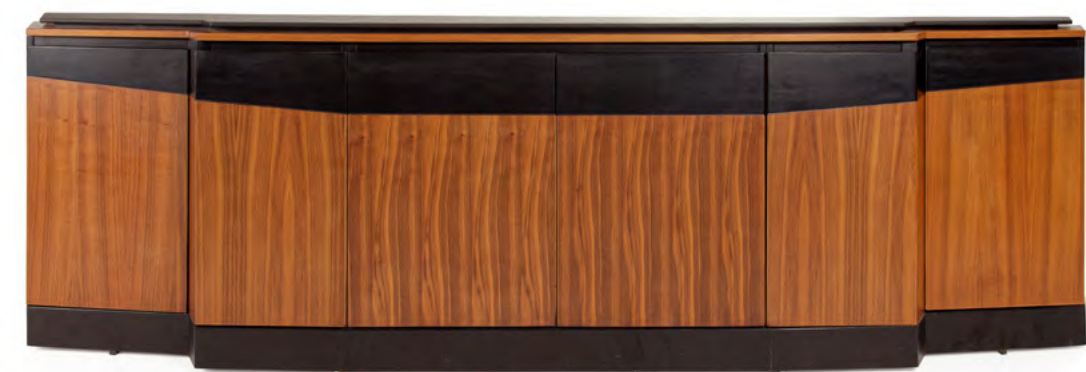

A matching credenza with the same automotive inspired lines of the Vencedor desk. The design is quite unique and stands out projecting an air of status and power. Due to the carefully divided interior of the cabinet this credenza happens to be quite functional in terms of storage capacity. This credenza is perfect to be matched with the Vencedor desk and even when used separately in a lounge setting it still projects an air of power and domination.



Vencedor



Technical Specifications

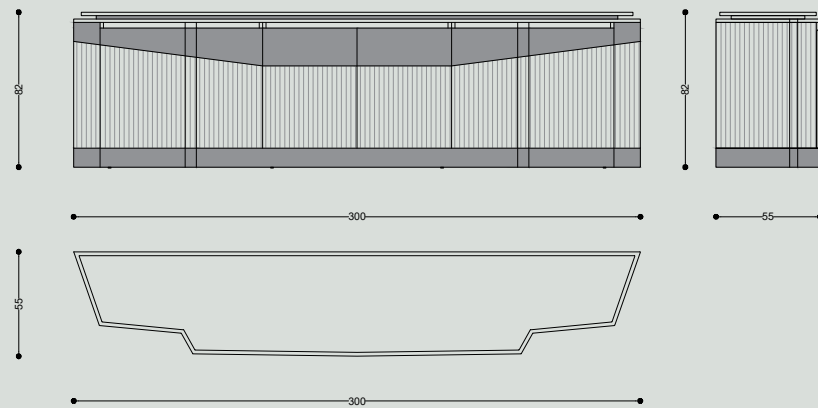

Materials : *MDF with natural wood veneer, water base finish, leather.*





03 | Console & BookShelfs



Troy Storage

Designed by: Ebony & Ivory Design Studio.



A minimal and simple storage cabinet that works with the Troy desk set or even separately within any meeting or common space, composed of horizontal and vertical natural veneer surfaces along with lacquered cabinet doors. The configuration with part open and part closed makes it less stagnant and more appealing.



Technical Specifications

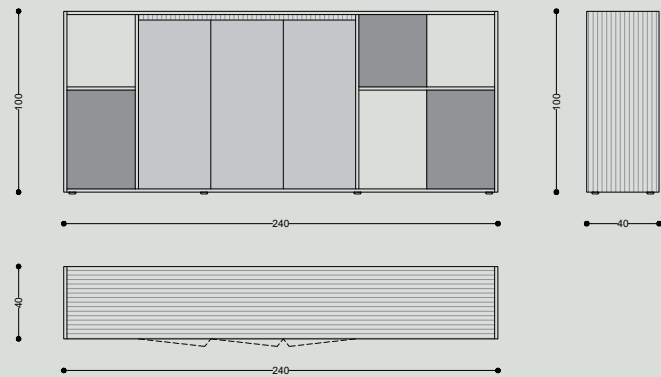

Troy Storage



Materiels: *MDF with natural oak veneer, lacquered panels, water base finish.*

Troy Shelving

Designed by: Ebony & Ivory Design Studio.



Simple lines joined vertically and horizontally with panels cleverly staggered along the back in lacquer. The composition is quite minimal and makes the final appearance quite reliant on the organized and decorative content featured within. This shelving unit works with the Troy desk set as well as separately within any lounging space or common area.



Technical Specifications

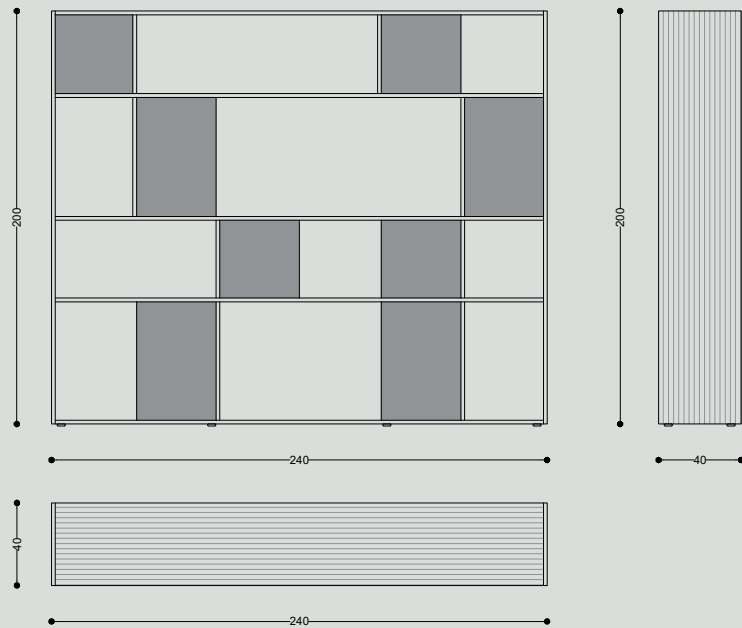

Troy Shelving



Materials: *MDF with natural oak veneer, lacquered panels, water base finish.*





Tide

Designed by: Kyme.



Water is omnipresent, moving through time and space. This carefully crafted wooden desk / console reflects the effortless liquid; its curved layered top along with its crafty fluid base come together into a timeless and sleek product for your daily life.

Multi-Office - Executive





Tide



Technical Specifications

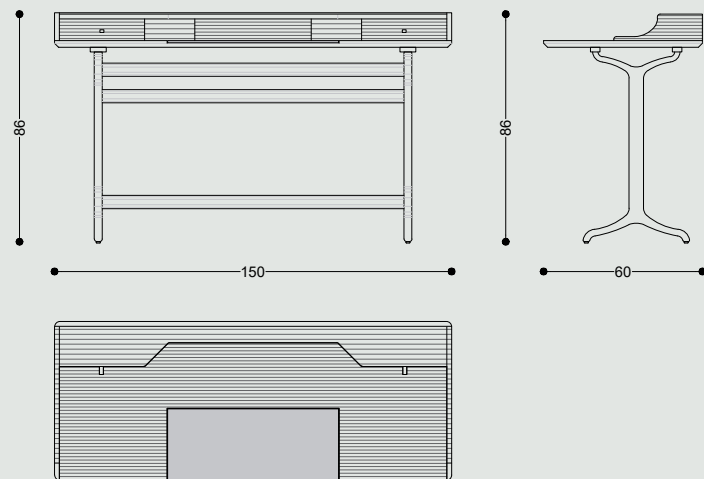

Materials: Solid beech structure, surface made of MDF with natural wood veneer, water base finish.



Webbing Console

Designed by Kyme.



This Console is the embodiment of a contemporary spider web. The product is made out of wood and glass. Its wooden parts are intricately entwined and connected, resembling that of the web. Transcending the natural world, the extracted patterns are reinvented into an iconic and practical design.



Technical Specifications

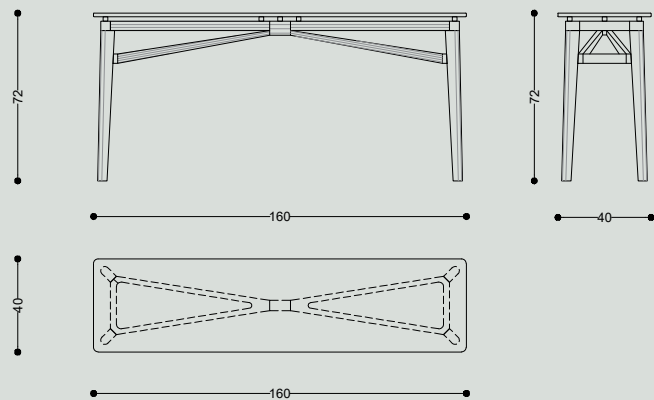

Webbing Console



Materials : Solid Beech wood structure, stainless steel inserts with PVD coating, 1.5 cm thick glass.





Knowledge Bird Cage

Designed by: Kyme.



The knowledgeable Bird Cage is inspired by the classic bird cage, fusing different genres of literature. The melodic sounds of the song-birds are a collection of audible works of art; which resonates with the wooden bookshelf, a body of written works. Hence, the bird cage could be used as a harmonious corner of literature, art and design.



Technical Specifications

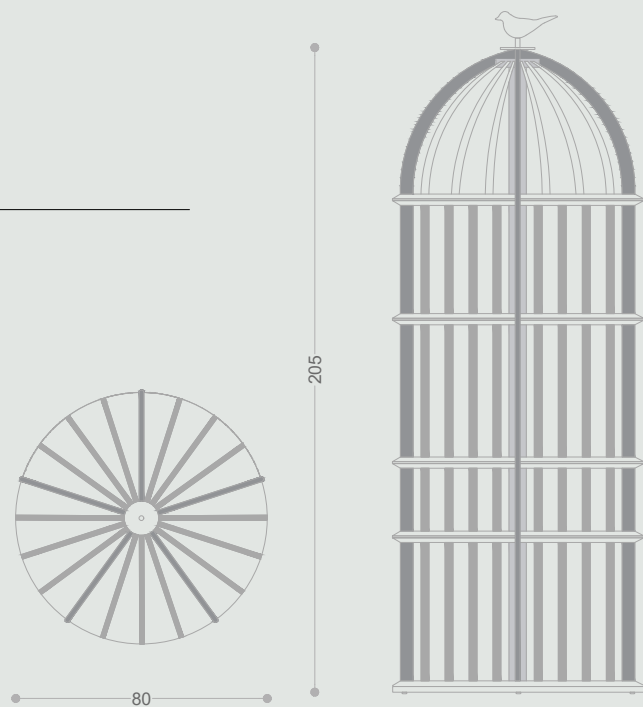

Knowledge Bird Cage



Materials: Solid beech structure, oak veneer.



اسر



COMMONSPACE

Counters & Cabinets

Meeting

Lounge

Tables





01 Counters & Cabinets

Zagel Counter

Zagel Cabinet

Zagel Counter

Designed by: A for Architecture.



The design concept stems from two different yet very noticeable Cairene daily life traits; Cairo's marvelous wooden dove towers with their striking colors and geometrical patterns, and the colorful street food carts where people gather to eat and chat. The two pieces have a common purpose, they act as stations of gathering and capturing special moments. The Zagel counter is an adaptation of the above combined, bringing the same energy and purpose to the work space, either in the form of a welcoming reception desk or in the form of communal multi-purpose high tables for breakout areas.



Zagel



Technical Specifications

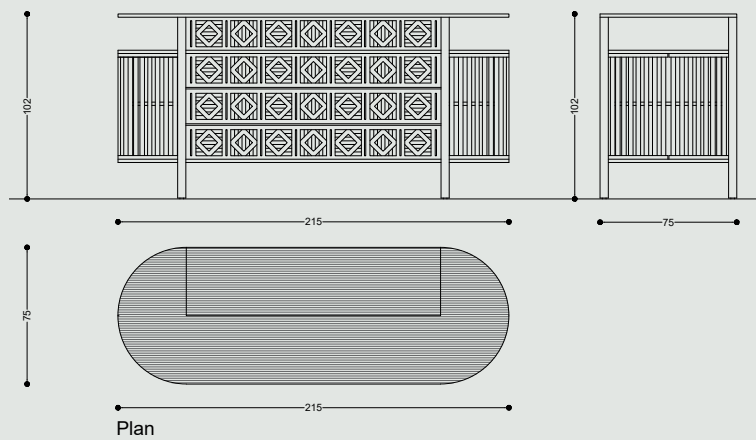

Materials : Solid beechwood, MDF with natural wood veneer, water base finish.

Zagel Cabinet

Designed by: A for Architecture.



The design concept stems from two different yet very noticeable Cairene daily life traits; Cairo's marvelous wooden dove towers with their striking colors and geometrical patterns, and the colorful street food carts where people gather to eat and chat. The two pieces have a common purpose, they act as stations of gathering and capturing special moments. The Zagel cabinet is an adaptation of the above combined, bringing the same energy and purpose to the work space.

Zagel



Technical Specifications

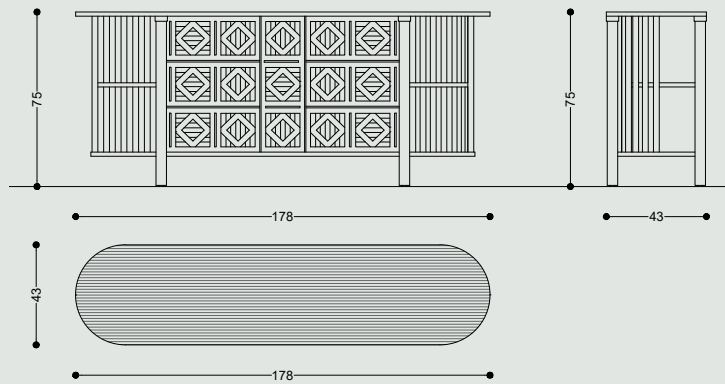

Materials : Solid Beechwood, MDF with natural wood veneer, water base finish.





02 | Meeting Tables



Eternal Flower



Eternal Flower

Designed by: Ebony & Ivory Design Studio.



A rich and playful board meeting table with a skillfully patterned surface made of natural Oak veneer, while the base is looking like tree trunks composed of solid Beech circular strips. The design of the table is formal yet cheerful, projecting an elegantly informal appearance. The infrastructure of the table is fully equipped with trays for power intercept units and cabling.



Technical Specifications

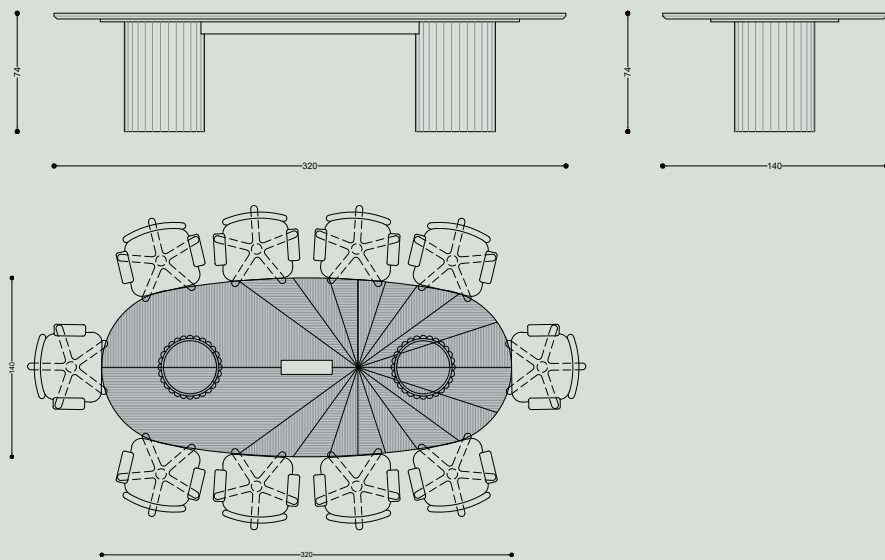

Eternal Flower



Materials: *MDF with natural wood veneer, water base finish, table base with solid beech wood.*



Cone

Designed by: Ebony & Ivory Design Studio.



A small round meeting table with a diameter ranging from 90cm - 120 cm , making it suitable for managerial rooms as well as small meeting rooms. The base of the table is conical with a metal base underneath for added stability. The hollow base structure provides support as well as enables cabling to reach the top surface . Base could be either painted or veneered, while the surface is always covered with natural Oak veneer, adding richness to the space where it gets located.



Technical Specifications

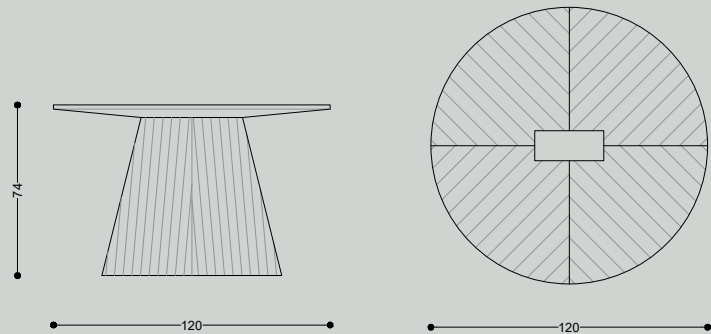

Cone

Designed by: Ebony & Ivory Design Studio.



Materials: *MDF with natural wood veneer, water base finish, metal base plate with electrostatic finish.*



Wing

Designed by: Ebony & Ivory Design Studio.



A luxurious meeting table with a design that mixes elements of creativity, practicality and comfort all in one. With its wooden patterned finish, design oriented base and two access doors for cable management this table is quite a center piece that adds sophistication to the board meeting Room.



Wing



Technical Specifications

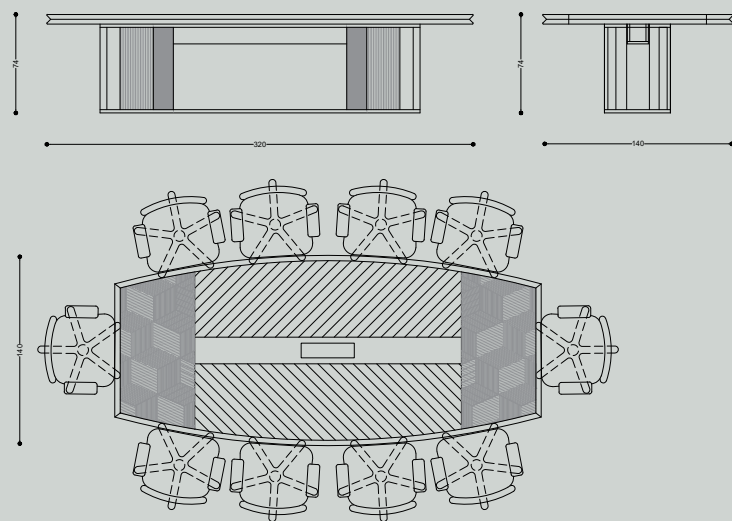

Materials: MDF with natural wood veneer, water base finish.



Scale

Designed by: Ebony & Ivory Design Studio.



This meeting table is available in custom sizes and features a simple rectangular shape supported by two pedestals with access doors for cable management. The tabletop is crafted from natural wood veneer and includes a central pad equipped with a power intercept unit for added functionality.



Technical Specifications

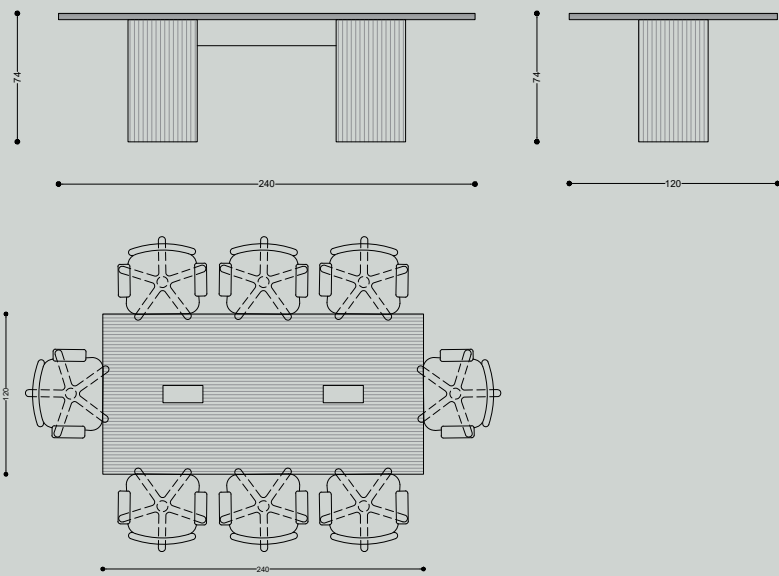

Scale



Materials: *MDF with natural wood veneer, water base finish.*





Modular Meeting Table



Modular Meeting Table

Designed by: Ebony & Ivory Design Studio.



A classical design composed of modular units finished with natural Oak veneer to be added together with custom sizes and dimensions to form a board meeting table with a hollow center for the sake of enhancing visibility between the attendees. The table is always equipped with cable runners to solve wiring problems. The surface always has power intercept units and could also feature microphones ..etc. for modern day communication.

Materials : *MDF with natural wood veneer, water base finish.*



alfonso

TRAPEZOID



Trapezoid

Designed by: Ebony & Ivory Design Studio.



This meeting table doubles as a creative architectural statement. Its slanted legs and unique assembly make a bold impression, further accentuated by the base's outline, which cuts through the surface and features a contrasting color for a decorative effect. The Trapezoid design serves as a focal point in any space, with the added functionality of a surface-mounted intercept unit equipped with power and data outlets.



Technical Specifications

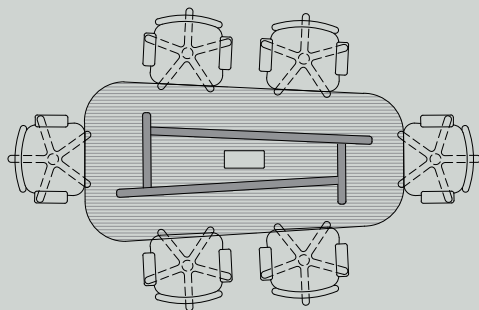
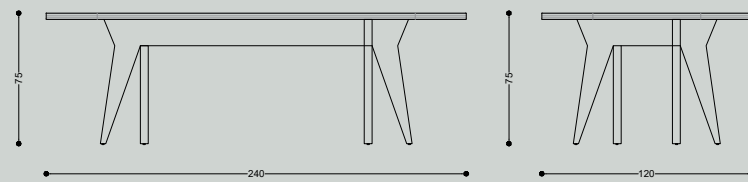

Trapezoid



Materials: *MDF with natural wood veneer, powder coated lacquered wood, water base finish.*



WorkBench Meeting Table

Designed by: Ebony & Ivory Design Studio.



A modular meeting table composed of the sturdy metal structure of the Work Bench metal support system. The modular nature offers diverse possibilities of size, shape and layout. This line's standout feature lies in its meticulously engineered metal components, ensuring robust mechanical fixation for enhanced durability and functionality. Depending on the layout and composition of the table cable management could be planned to maintain a clean organized appearance.



Technical Specifications

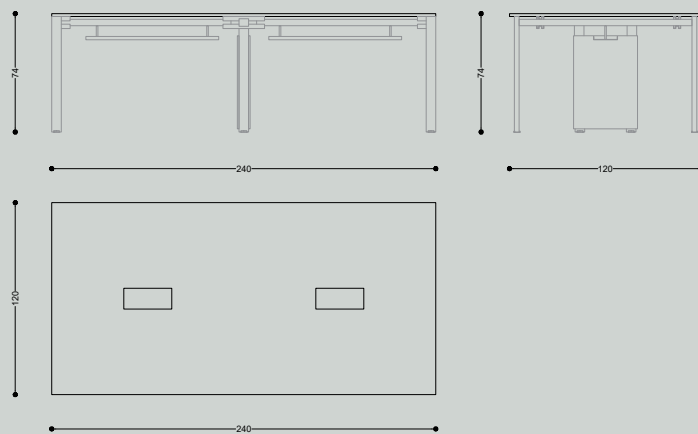

WorkBench Meeting Table

Designed by: Ebony & Ivory Design Studio.



Materials: *MDF with high pressure laminate and 2mm PVC trims, metal base and structure with electrostatic finish*



WorkBench Round

Designed by: Ebony & Ivory Design Studio.

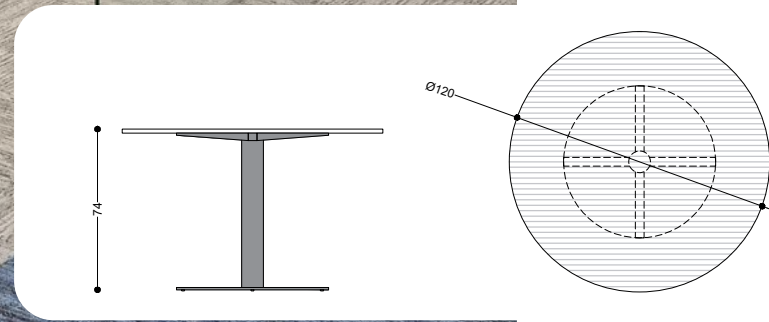

The perfect proportion for a small meeting room, a round surface finished either in natural veneer or HPL supported on a stable monopod. The table could also be used to create a small meeting area in managerial rooms.



Technical Specifications

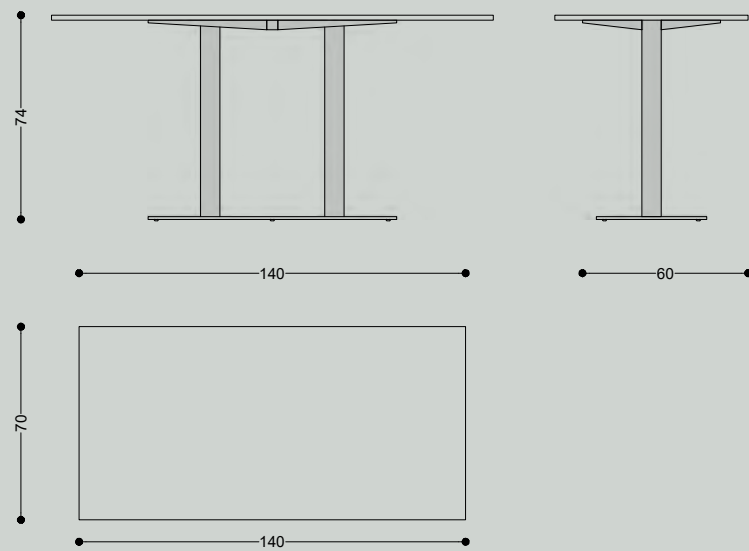

Cantilever

Designed by: Ebony & Ivory Design Studio.

This is a minimalist meeting table featuring a laminated surface mounted on a sturdy metal base supported by two poles. The design prioritizes simplicity while effectively fulfilling its purpose.



Materials: *MDF with high pressure laminate, metal base with electrostatic finish.*







03 | Lounge





03 | Lounge





03 | Lounge





Polygon

Designed by: Ebony & Ivory Design Studio.



An outstanding geometric design with eye-catching architectural details, the body of the sofa is understated to provide comfort while sitting, whereas the arms really make a statement, adding an artistic flair to any space.



Polygon



Technical Specifications

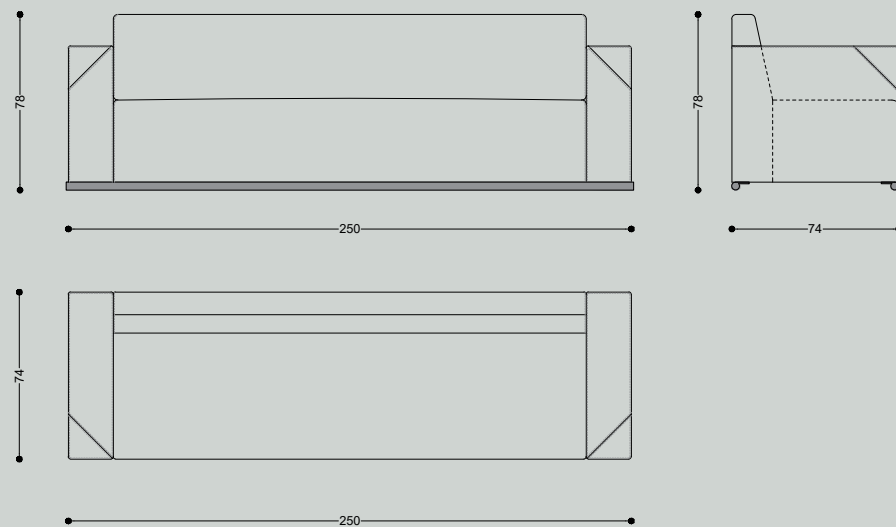

Materials: Solid wood structure, zigzag springs, layered foam in different densities, fiber lining, fabric / leather.



Oud

Designed by: Ebony & Ivory Design Studio.



A beautiful sofa to view from all angles, back and sides are covered with natural wood veneer giving it richness and elegance. Oud is the perfect lounging piece of furniture for corporate space lounges, it also offers an interesting opportunity to be used as a free-standing object in the middle of a lounging space while it shows off the beauty of its natural veneer shell.



Oud



Technical Specifications

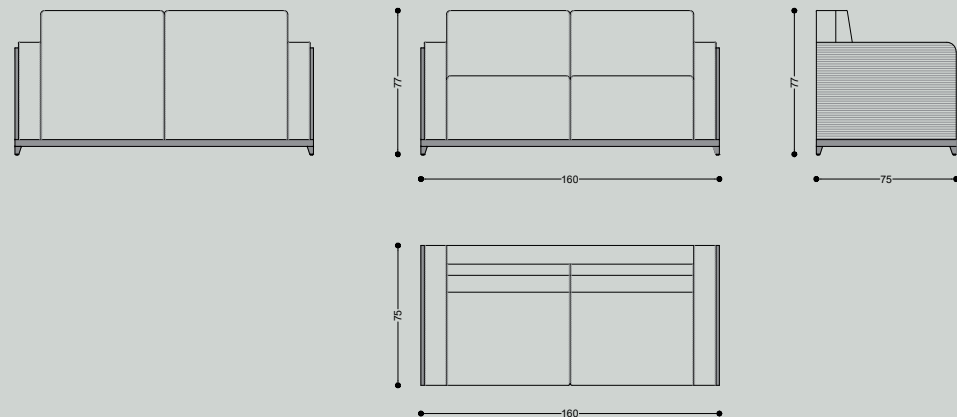

Materials: Solid wood structure, MDF with natural wood veneer, water base finish, zigzag springs, layered foam in different densities, fiber lining, fabric / leather.



Dash

Designed by: Ebony & Ivory Design Studio.



The Dash is the most popular sofa in the Alphabet office lounge collection. Its padded seat and back, combined with the elegant capitonné detailing, offer sophistication and style that surpasses the typical plain office lounge sofa. The seat and back cushions are crafted with upholstered wooden frames securely attached to the sofa's wooden structure, making them non-removable. The base is available in two options: solid hardwood or sleek stainless-steel legs.



Dash

Technical Specifications

3 Seaters Sofa

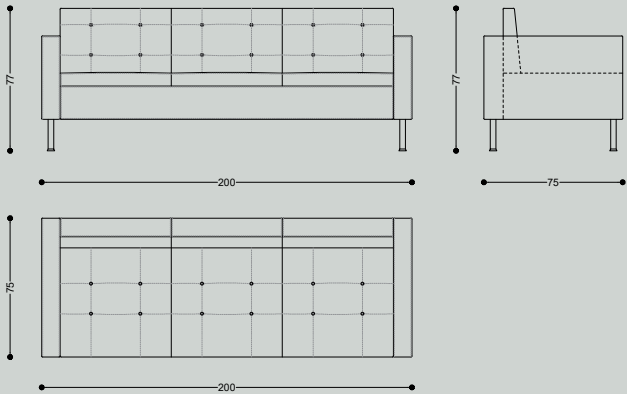

2 Seaters Sofa

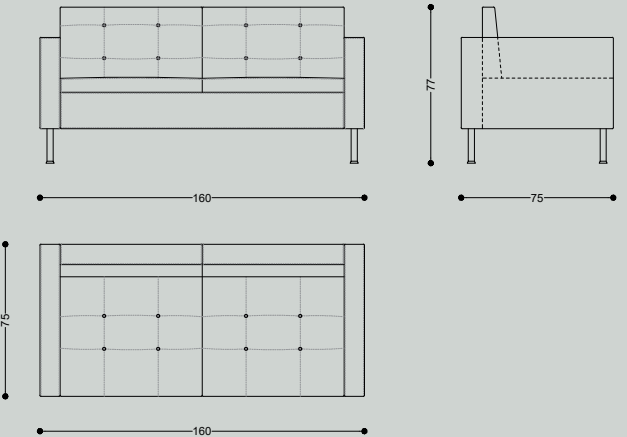

Materials: Solid wood structure, zigzag springs, layered foam in varying densities, fiber lining, fabric / leather, stainless steel legs.



Dash



Technical Specifications

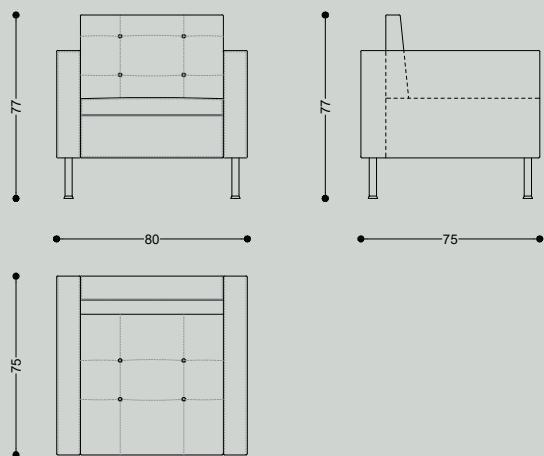

Materials: Solid wood structure, elastic belts, layered foam in varying densities, and fiber lining.

TRIM

Designed by: Ebony & Ivory Design Studio.



Even though it's a cubic sofa which mainly intends to provide comfort, due to the careful design details done by rethinking all the relations between the back, the arms, the back cushions and the seat, this sofa ended up gaining substantial formality and elegance. The solid wood base of the sofa with the layering of the wood and the trim further add to the elegance and formality of the sofa, making it a perfect choice for salons and sophisticated public lounges.





TRIM



Technical Specifications

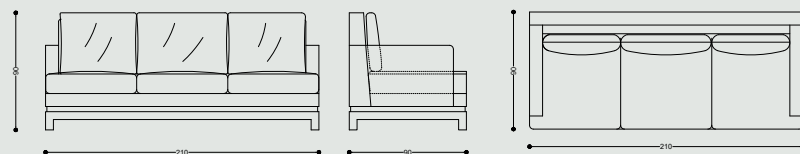
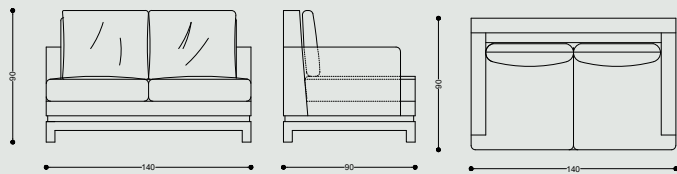

Materials: Hardwood base, solid wood structure, zigzag springs for the seat, elastic belts for the back, layered foam with various densities, dacron polyester fiber lining.

Twirl

Designed by: Ebony & Ivory Design Studio.



A skillfully built organic looking L-shaped sofa. The shape offers flexibility when it comes to creating interior space layouts. The relation between the seat and back and the way all details and curves are designed and crafted give this piece a very aesthetically pleasing visual when viewed from all angles. Twirl is a lounging sofa that could be used in residential spaces as well as public areas and spaces where socializing is to be encouraged.

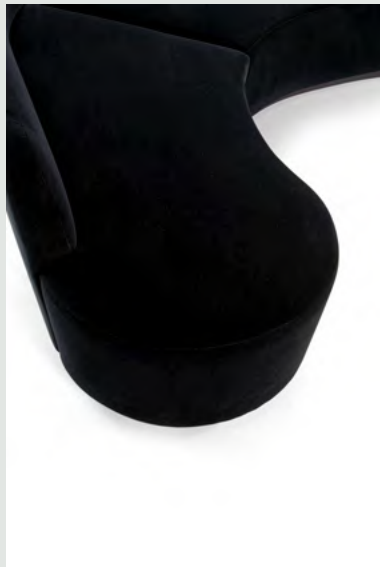

Technical Specifications

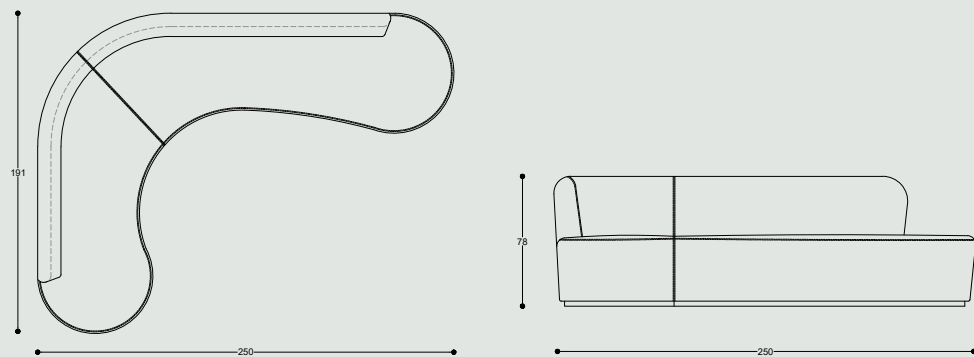

Twirl



Materials: *Hardwood base, solid wood structure, zigzag springs for the seat, elastic belts for the back, layered foam with various densities, dacron polyester fiber lining.*



Arc

Designed by: Ebony & Ivory Design Studio.



This elegant kidney shaped sofa with its curved front and back make it the perfect salon sofa due to its elegance and sophistication. Careful proportions and angles offer comfort and formality joined together. With its organic shape it's quite pleasing to the eye to view it from all angles, which makes it attractive if placed in the middle of a hall with its back exposed.



Arc



Technical Specifications

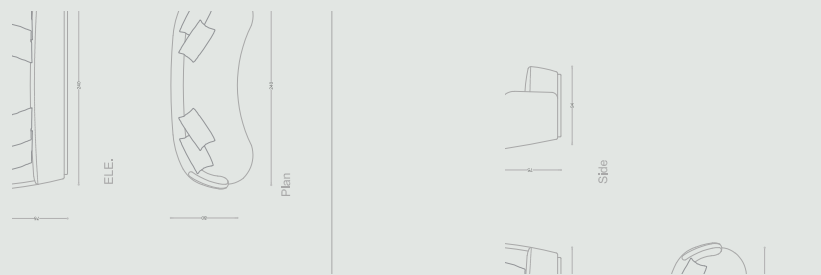

Materials: *Hardwood base, solid wood structure, zigzag springs for the seat, elastic belts for the back, layered foam with various densities, dacron polyester fiber lining.*



Spin

Designed by: Ebony & Ivory Design Studio.



Smooth curves form this outstanding organically shaped sofa. Skillfully assembled and crafted, this sofa offers different lounging experiences due to the irregularity of its width. Perfect when located in the middle of a lounging hall, mostly suitable for public areas and reception halls.



Spin



Materials: *Hardwood base, solid wood structure, zigzag springs for the seat, elastic belts for the back, layered foam with various densities, dacron polyester fiber lining.*

Technical Specifications

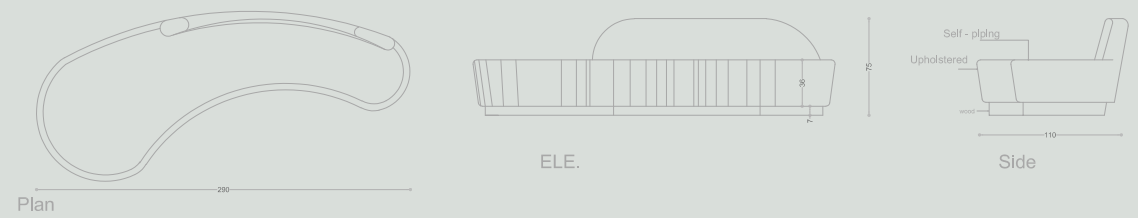

Ballast

Designed by: Monty Design.



The Ballast shares some design lines with the Vencedor executive desk, and complements the concept with automotive inspiration. Ballast means the element of stability, which is clearly visible by just looking at the sofa. It features a design element never before used in any sofa, which is that the armrests are surpassing the depth of the seat, which gives it that bold and stable look.





Ballast



Technical Specifications

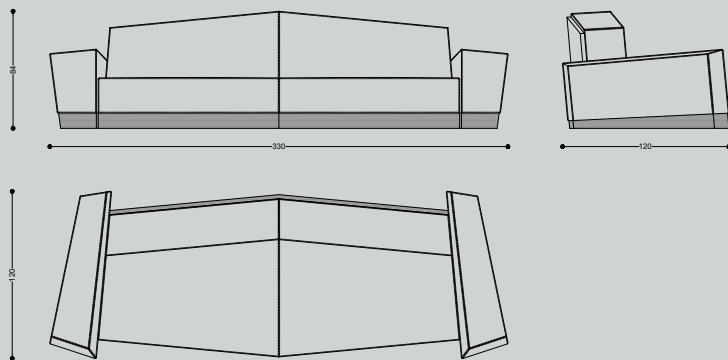

Materials: Solid wood structure, zigzag springs, layered foam in varying densities, fiber lining, fabric / leather.



Dawn



Dawn

Designed by A for Architecture.



Dawn lounging set is inspired by Cairo's dawn moments, where the sun rises above the charming city. A main half circular upholstered back rest rises as a direct symbol of the sun amongst differently sized lower fixed back rests and other loose cushions, turning Cairo's chaos into a comfortable sofa.



Technical Specifications

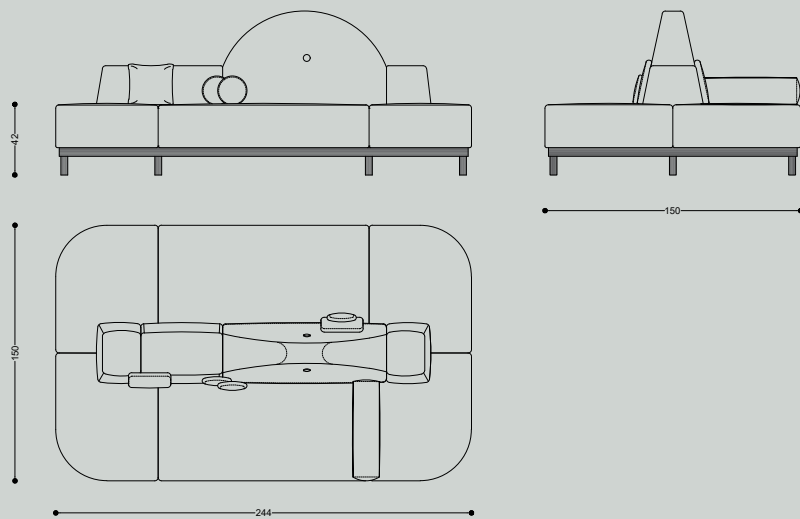

Dawn



Materials : Solid wood structure, zigzag wires, layered foam in different densities, fiber lining, fabric or leather.



Alphabet OFFICE · Products

S-Cai

Designed by: A for Architecture.



Inspired from the Cairene very diverse skyline, S-Cai sets provide modular solutions, single as well as double sided waiting / informal workspace, seating islands with incorporated tables.



Technical Specifications

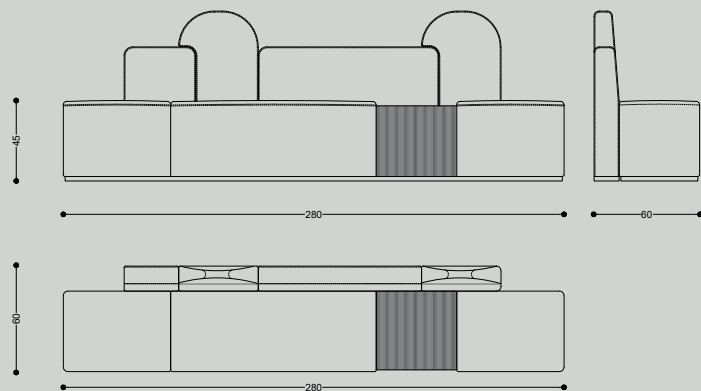

S-Cai



Materials : Solid wood structure, zigzag wires, layered foam in different densities, fiber lining, fabric or leather.



Pachas

Designed by: A for Architecture.



Inspired by the roundabouts of Cairo's downtown that were always named after 1900s' inspiring Egyptian Public figures like Talaat Harb, Mostafa Kamel, ... etc, Pashas waiting sets are an extrusion of Cairo's downtown landmark roundabouts and their surrounding architectural blocks.



Technical Specifications

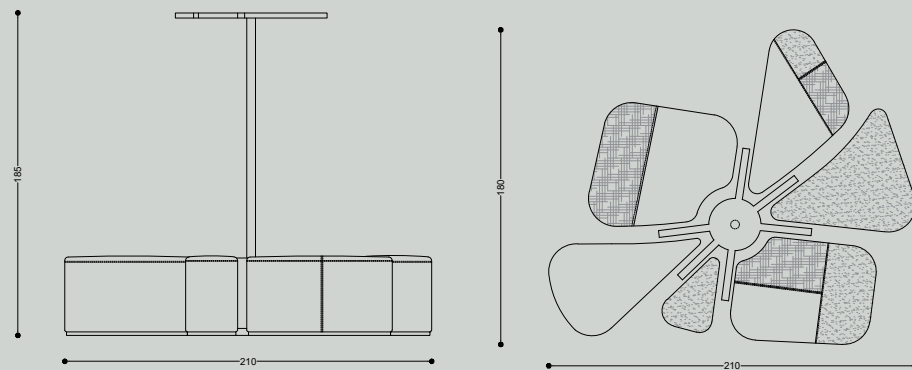

Materials : Solid wood structure, zigzag wires, layered foam in different densities, fiber lining, fabric or leather.





Soul

Designed by: Ebony & Ivory Design Studio.



Soul has been specially designed for breakout areas in large corporate spaces. The whole point of the proportion is to encapsulate whoever is sitting inside, while reducing sound transmission. It's comfortable enough for a corporate space sofa.



Soul



Technical Specifications

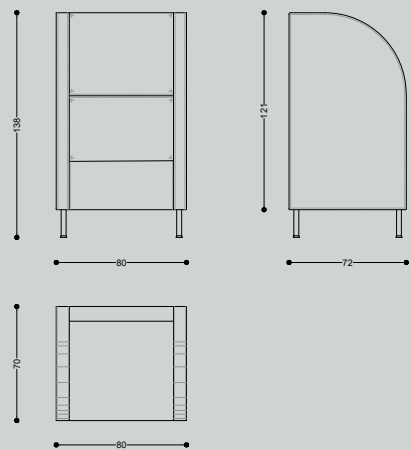

Materials: Solid wood structure, zigzag springs, layered foam in different densities, fiber lining, fabric / leather, stainless steel legs.



Technical Specifications

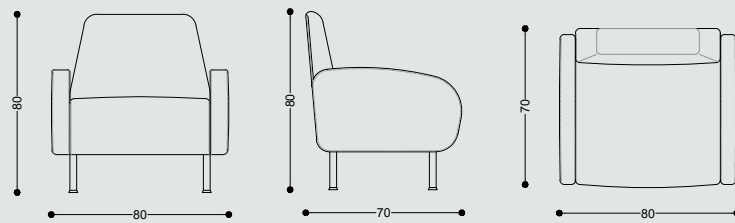

Abbas

Designed by: Ebony & Ivory Design Studio.



A comfortable lounging chair with subtle details. The design concept of Abbas is mainly based on the tapering of all its elements along with an upholstery technique that accentuates the puffiness of the foam padding. The end result is simple and comfortable as well as with character and strong presence.

Materials: Solid wood structure, zigzag springs, layered foam in different densities, fiber lining, fabric / leather, stainless steel legs.





Ali

Designed by: Ebony & Ivory Design Studio.



Sleek curves cleverly proportioned to support the right posture while sitting and dining. This chair is quite often joined with Friend on the dining table. The curved outlines match easily, and the combination offers visual diversity on the dining table that is harmonious at the same time.



Technical Specifications

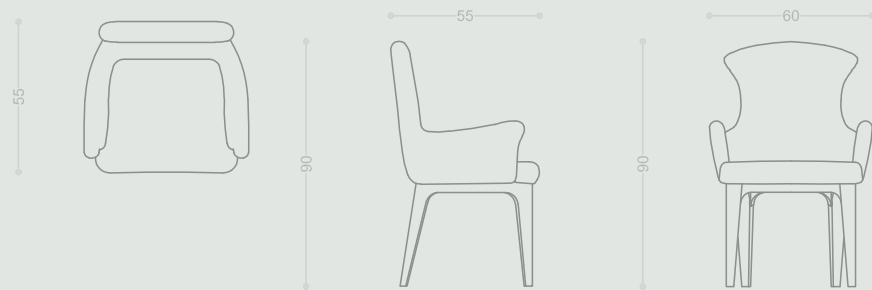

Ali



Materials: *Hardwood legs, plywood structure, elastic belts, layered foam with various densities, dacron polyester fiber lining.*



Scoop

Designed by: Ebony & Ivory Design Studio.



An upholstered shell sitting on a hardwood stand that is considerably smaller. This chair has the visual appearance of a display item, just like an artifact is held on a stand at a museum. The angles and the slant of the back are worked out carefully to make it comfortable. This chair could be used in any interior wherever the designer decides to break from regular looking objects.



Technical Specifications

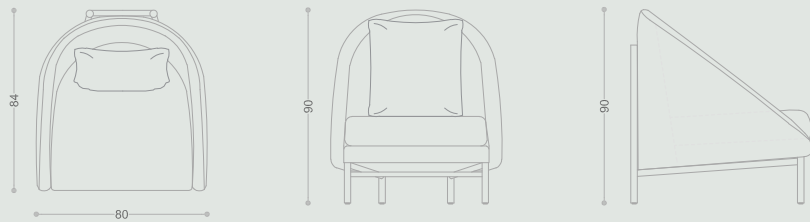

Scoop



Materials: Hardwood base, solid wood structure, zigzag springs for the seat, elastic belts for the back, layered foam with various densities, dacron polyester fiber lining.





Duetto

Designed by: Ebony & Ivory Design Studio.



The size of this chair is fitting somewhere between a big armchair and a small dining chair. The curving of the back and the way it joins into the arms of the chair, along with perfect slanting of the back offer a very comfortable lounging experience. Using this chair while furnishing a plan solves lots of problems whenever there is a space constraint just because of the small footprint it has. This chair could be used for both residential and contract spaces.



Technical Specifications

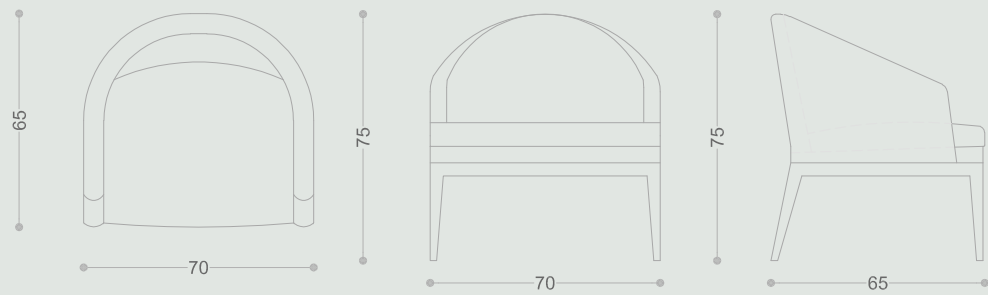

Duetto



Materials: *Hardwood base, solid wood structure, zigzag springs for the seat, elastic belts for the back, layered foam with various densities, dacron polyester fiber lining.*



Duetto II

Designed by: Ebony & Ivory Design Studio.



The size of this chair is fitting somewhere between a big armchair and a small dining chair. The curving of the back and the way it joins into the arms of the chair, along with perfect slanting of the back offer a very comfortable lounging experience. Using this chair while furnishing a plan solves lots of problems whenever there is a space constraint just because of the small footprint it has. This chair could be used for both residential and contract spaces.



Duetto II



Technical Specifications

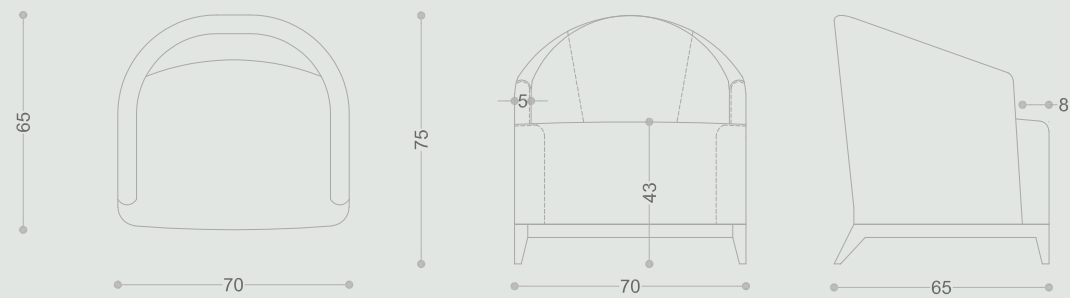

Materials: Hardwood base, solid wood structure, zigzag springs for the seat, elastic belts for the back, layered foam with various densities, dacron polyester fiber lining.



AlphabetOffice · Products

Karak

Designed by: Monty Design.



The Karak chair is a contemporary take on the legendary Thonet bistro chair. Karak is characteristic in its own right by Monty Design's famous straight and edgy lines. Contrary to its harsh and angular looks, Karak is ergonomically studied and is very comfortable and features an excellent back support, to make your long dining experiences as enjoyable as they could get.



Technical Specifications

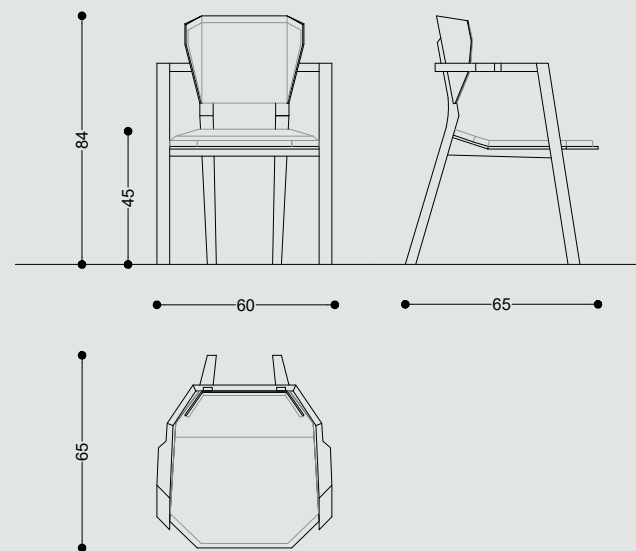

Karak



Materials: Solid wood structure, plywood, layered foam in varying densities, fiber lining, fabric / leather.



Posture chair

Designed by: Ebony & Ivory Design Studio.



A multipurpose chair composed of a metal wire structure with upholstered seat and back pads. This chair is sturdy with several usage possibilities for breakout areas as well as the possibility of it serving as a guest chair, it could also be equipped with a writing tablet for training.





Posture chair



Technical Specifications

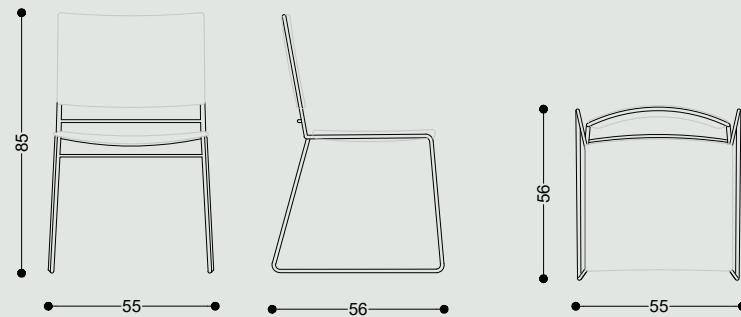

Materials: Solid metal wire with an electrostatic finish, plywood, layered foam with different densities, fiber lining, fabric / leather.





Technical Specifications

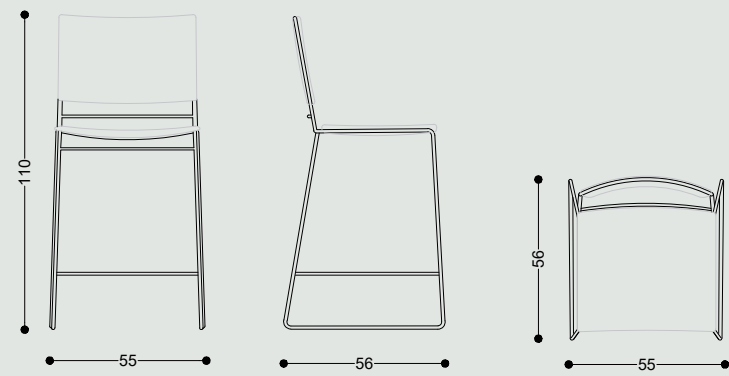

Posture high chair

Designed by: Ebony & Ivory Design Studio.



Materials: Solid metal wire with an electrostatic finish, plywood, layered foam with different densities, fiber lining, fabric / leather.





Skeleton chair

Designed by: Ebony & Ivory Design Studio.



A very minimal sculptural looking chair. The shape adds so much character to any interior with its tapered lines when viewed from all angles.



Technical Specifications

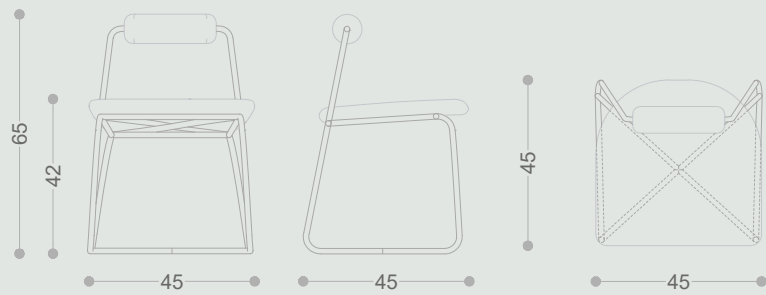

Skeleton chair



Materials: Solid metal wire with an electrostatic finish, plywood, layered foam with different densities, fiber lining, fabric / leather.



Skeleton high chair

Designed by: Ebony & Ivory Design Studio.



A very minimal sculptural looking chair. The shape adds so much character to any interior with its tapered lines when viewed from all angles.



Technical Specifications

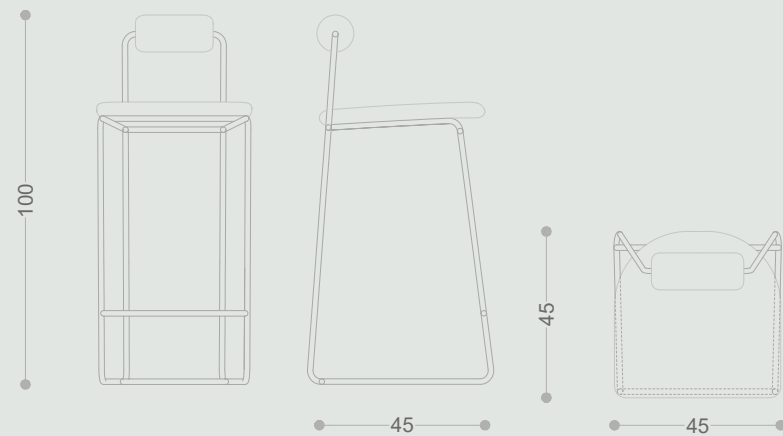

Skeleton high chair



Materials: Solid metal wire with an electrostatic finish, plywood, layered foam with different densities, fiber lining, fabric / leather.





Skiff chair

Designed by: Ebony & Ivory Design Studio.



An iconic design with the chair lines cut out of a pyramidal mass fading into a single point at the top, leading to the ancient egyptian insinuations within the chair's design lines. cut out of a pyramidal mass fading into a single point at the top, leading to the ancient egyptian insinuations within the chair's design lines. The chair is produced out of solid teak witch makes it perfect for the outdoors.





Technical Specifications

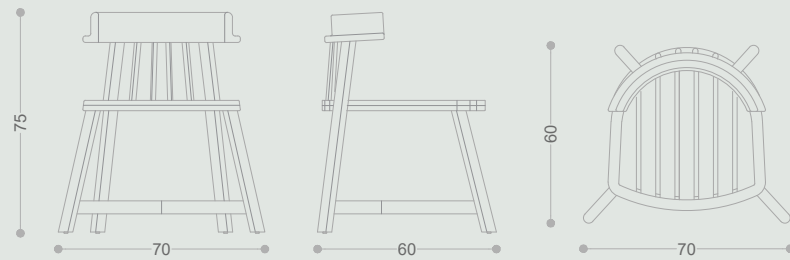

Skiff chair



Materials: Solid pitch pine.



Skiff bench

Designed by: Ebony & Ivory Design Studio.



Technical Specifications

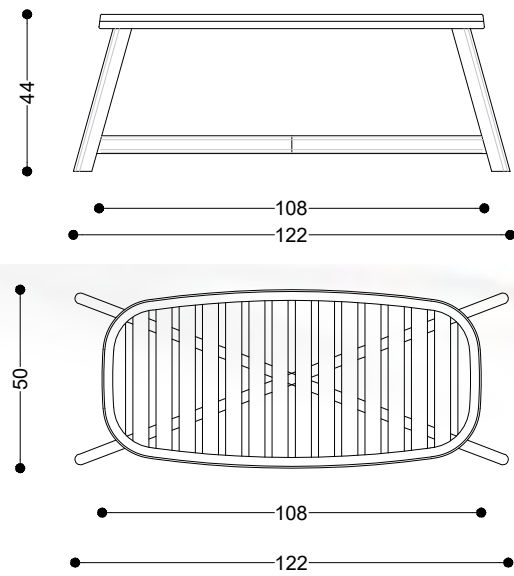

Materials: Solid pitch pine.



Wave

Designed by: Ebony & Ivory Design Studio.



Two modules of chairs, one completes the other creating a wave. A beautiful design idea that adds character and playfulness to the waiting hall. What makes Wave even more functional is that the single module allows a person to sit on both sides of the chair, either at chair level at the front, or stool level at the back. Wave is aesthetically appealing, functional and quite fun.



Wave



Materials: Solid wood structure, elastic belts, layered foam in different densities, fiber lining, fabric / leather.

Technical Specifications

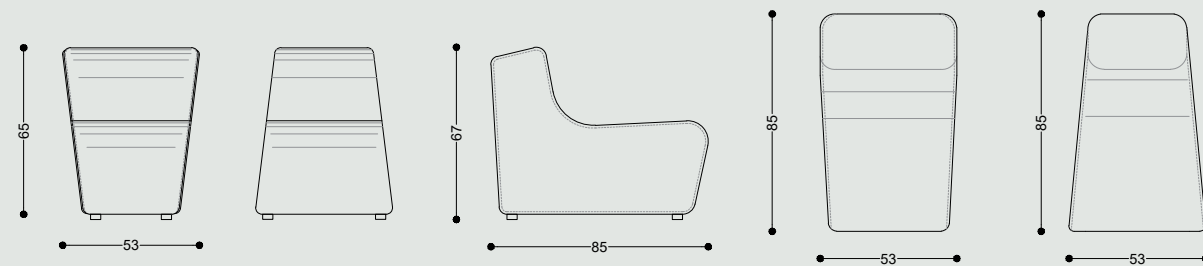



T-Bench

Designed by: Ebony & Ivory Design Studio.



This is a modular lounging line specially designed for waiting areas. It is available in 3 different modules offering flexibility while planning the layout of waiting halls. The tapering of the back, when repeated, creates a decorative array, making it inviting for designers to play around with the layout, the more they do, the more the configuration becomes playful and unique.



T-Bench

Materials: Solid wood structure, elastic belts, layered foam in different densities, fiber lining, fabric / leather, stainless steel legs.



Technical Specifications

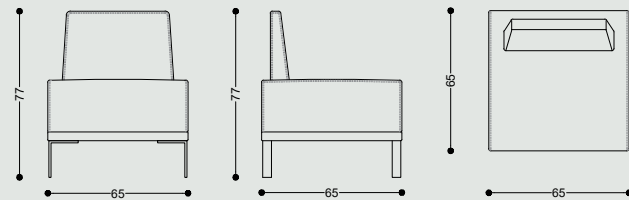

Technical Specifications

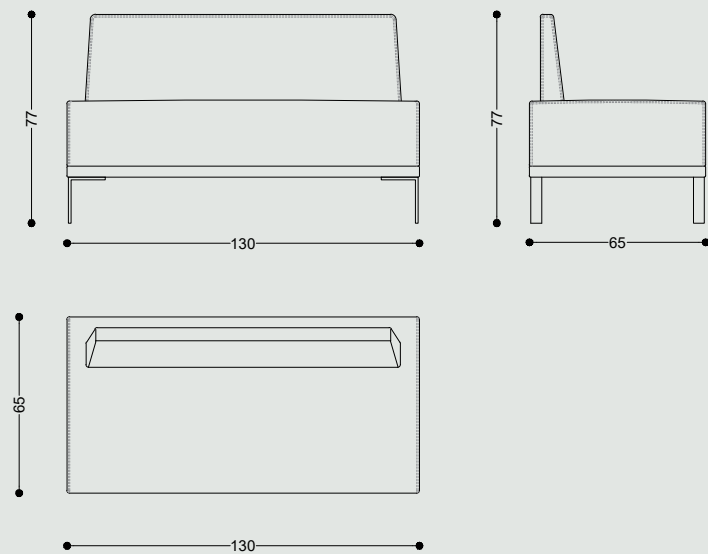



Horse

Designed by: Ebony & Ivory Design Studio.

A feature pouf with an attached tablet, perfect for public areas. The detailing of the overlap between the tablet and the actual seat, with the repetition on of shape turn this pouf into an attractive visual gesture within any context.

Technical Specifications

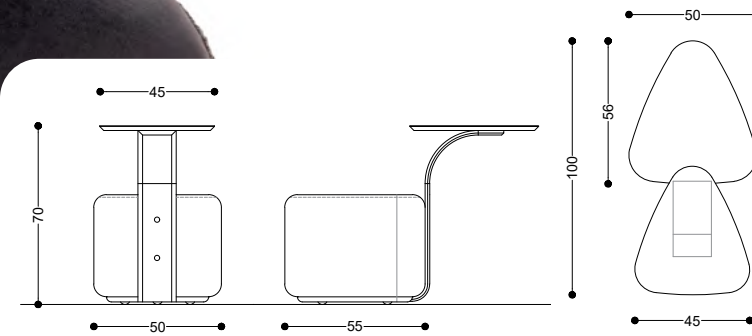

Materials: *MDF with natural wood veneer, water base finish, foam padding, castors, fabric / leather.*



Case

Designed by: Ebony & Ivory Design Studio.



Technical Specifications

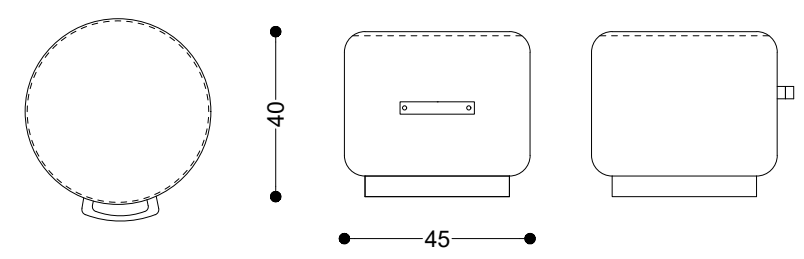

A simple round pouf with a basic cylindrical shape, the wooden base along with the wooden arms add character and give a chance to mix different finishes to make it stand out. The structure of the pouf is carefully engineered to make it sturdy yet light in weight at the same time. This simple furniture piece offers so much possibilities within any interior context.

Moon

Designed by: Ebony & Ivory Design Studio.

A circular pouf with the basic shape of a cylinder, the top cushion is made of an upholstered wooden frame fixed on the pouf for practicality. Full moon is an occasional piece within the office space, could be used anywhere, not necessarily the lounge. Having it on castors makes it easy to slide around for ease of movement.



Technical Specifications

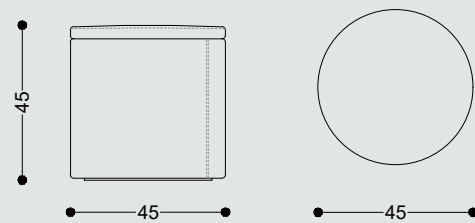

Materials: Solid wood structure, plywood, elastic belts, layered foam in different densities, fiber lining, fabric / leather, castors.





04 | Tables



Zeppelin

Designed by: Ebony & Ivory Design Studio.



A simple cylindrical shape. Due to the basic geometry of this table, it easily fits modern, traditional and contract spaces.

Materials: *Solid hard wood, natural wood veneer.*

Technical Specifications

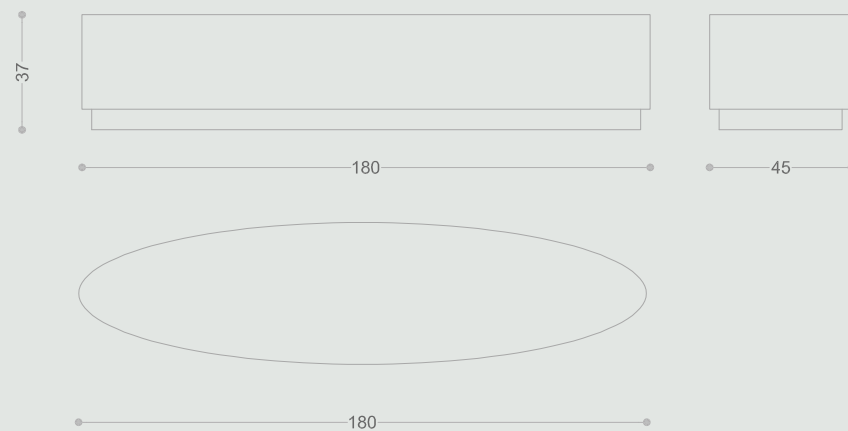



Ray

Designed by: Ebony & Ivory Design Studio.



This cocktail table is a marquetry masterpiece. A sun burst pattern spreading from the center of the table, travelling to the edge of the surface then again travels further down the body of the table till it reaches the base. The design shows off the craftsmanship used in production for a fully handmade piece. This table has strong presence anywhere, creating a very attractive focal point to any lounging space.



Technical Specifications

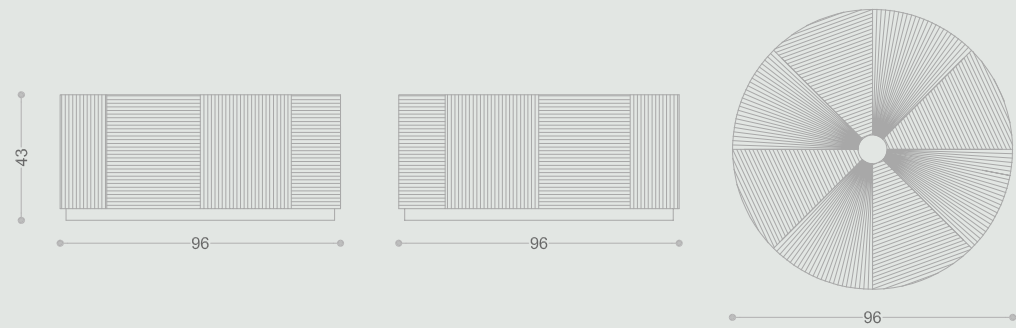

Ray

Designed by: Ebony & Ivory Design Studio.



Materials: *Solid wood structure, natural wood veneer.*



Wheel

Designed by: Ebony & Ivory Design Studio.



A simple cylindrical metal shell, available in two diameters depending on whether it is a side table or a center table. The tubular frame of the metal shell adds an attractive basic retro feel to the table. Wheel could be used anywhere within an office space; it could also be used in public lounges and homes.

Materials: *MDF with high pressure laminate, metal base with an electrostatic finish.*

Technical Specifications

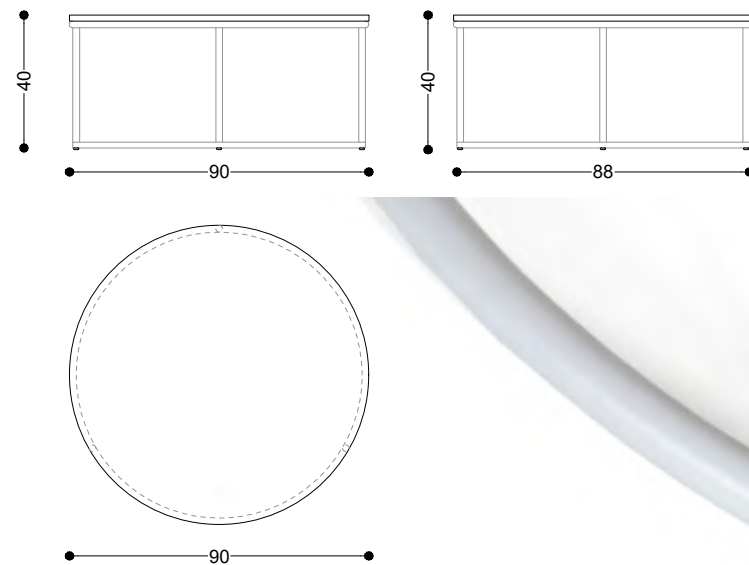



Skiff

Designed by: Ebony & Ivory Design Studio.



A simple yet functional table made of solid Teak to make it suitable for the outdoors. The gaps in the surface are intentional for functional aspects. The Skiff table is best used with both the Skiff chair and the Skiff bench.

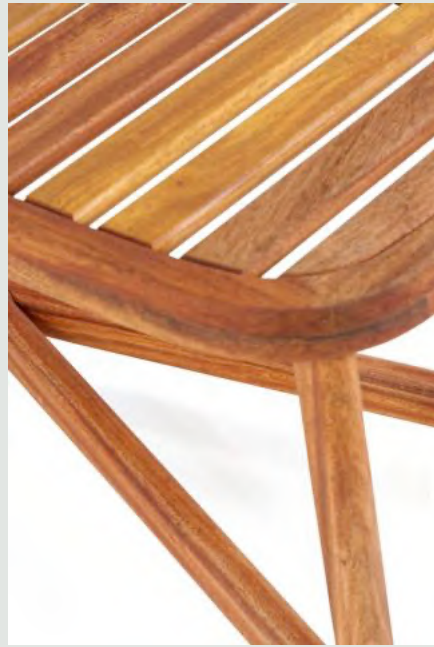

Technical Specifications

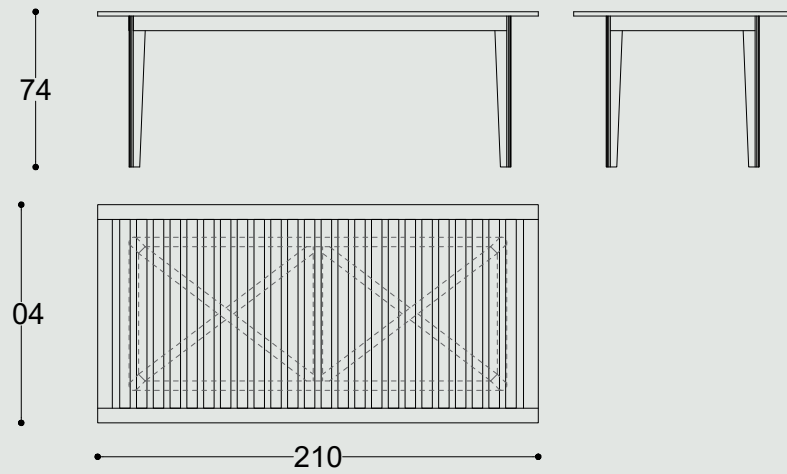

Skiff



Materials: Solid pitch pine structure and surface.

Crate

Designed by: Ebony & Ivory Design Studio.



Materials: Solid beech wood, MDF with natural wood veneer, water base finish.

A square top with a basic chamfered wooden base supporting it. Because of the table fitting a clearly defined module, more than one could be added together to form a bigger array and create a big center table. This design is basic enough to fit both residential and contract spaces.

Technical Specifications

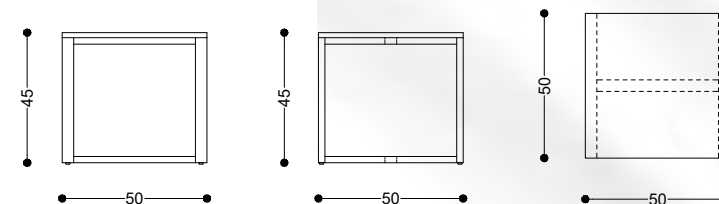

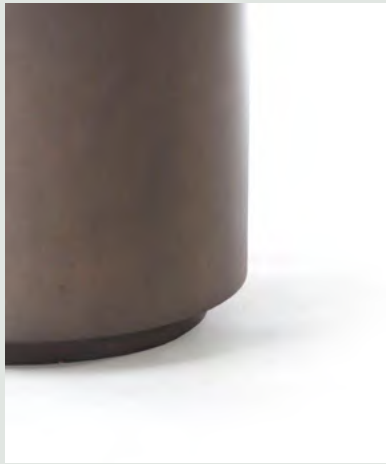

Technical Specifications

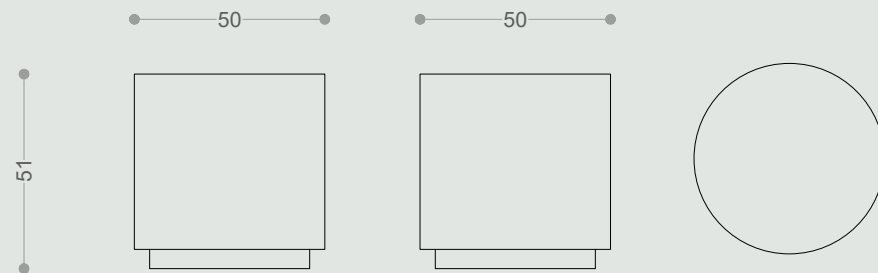

Drum

Designed by: Ebony & Ivory Design Studio.

A simple cylindrical shape. Due to the basic geometry of this table, it easily fits modern, traditional and contract spaces.



Materials: Solid hard wood, natural wood veneer.





Forge

Designed by: Ebony & Ivory Design Studio.

The metal base is fully composed of 2cm x 2cm welded square sections, which makes this table look and feel quite sturdy even when the section used is quite thin. The vertical and horizontal parallel lines of the base render this table in basic geometric principles. The surface is made of natural wood veneer in a pattern that echoes the concept of the base by adding the two parallel lines made of another type of natural veneer.



Technical Specifications

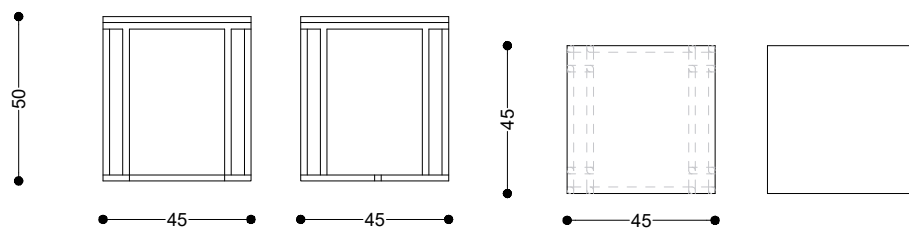

Materials: *MDF with natural wood veneer, metal base.*

Scaffold

Designed by: Ebony & Ivory Design Studio.

The design concept is simple yet remarkable, the detail of the overlapping v-shaped supports is what gives this table character and sturdiness at the same time.



Technical Specifications

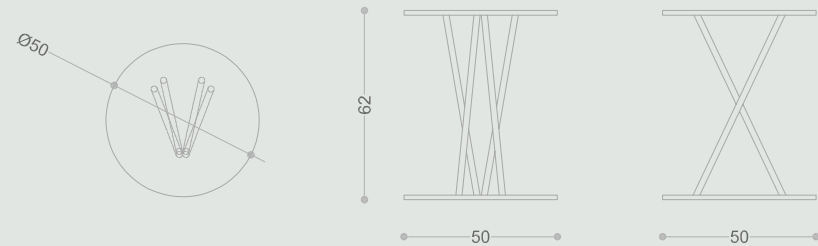

Materials:

Solid hard wood, MDF disks veneered in natural wood veneer.



Hexa

Designed by: Ebony & Ivory Design Studio.



Materials: Solid ash base, surface covered with natural Walnut veneer.

Technical Specifications

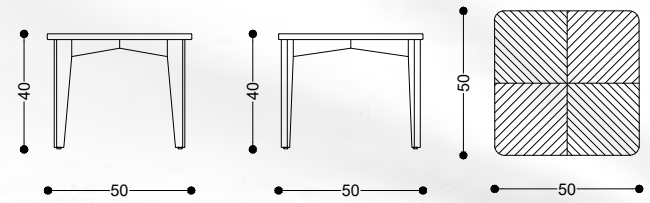

A simple design, the surface has a basic shape, the whole concept of this table is done by the angles created with the legs along with their supporting brackets. This table could be used for both residential and contract spaces, available as both; a cocktail center table and a square-shaped side table.



Offices Design & Furniture
The CATALOG 2025

HEAD OFFICE

208 Adly St.
Kodak Passage
Downtown, Cairo, Egypt.

CAIRO SHOWROOM

TAMARAHAUS
17 Gawad Hosny St.
Downtown, Cairo, Egypt.

SOMABAY SHOWROOM

Shop No. 1
Marina, Soma Bay,
Redsea, Egypt.

FACTORY

Industrial Zone B4,
10TH of Ramadan city.
Egypt.

TELEPHONE

02 127 111 9830
